

MagicDrill **DRV**

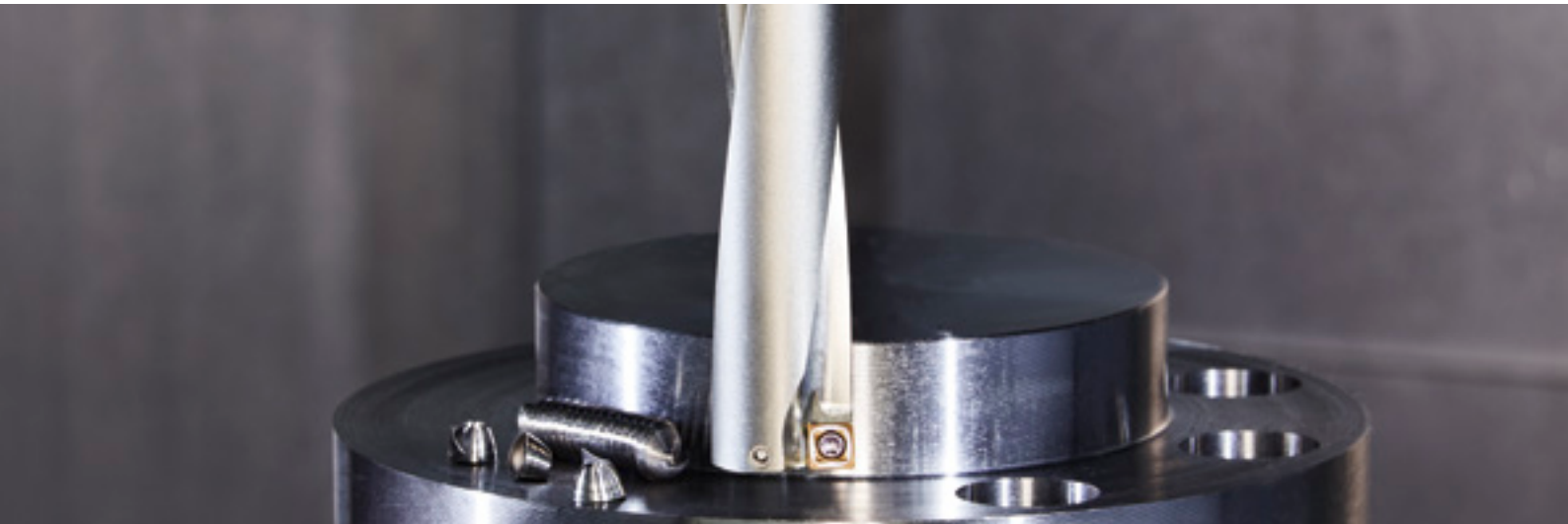

Economical inserts with 4 cutting edges
Excellent chip evacuation with 6D maximum deep-hole drilling

2D to 6D drilling line-up and 4 types of chipbreakers for various machining applications.

High speed and highly efficient machining available with the combination of a CVD outer insert and PVD inner insert.

Highly rigid design with chattering resistance.
Excellent hole accuracy.

DRV chamfering attachment.

NEW DLC coating for aluminium alloy machining

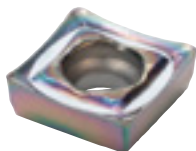

PDL025
(Outer edge)

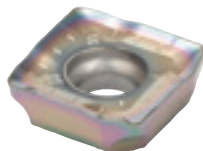

PDL035
(Inner edge)



**KEEPS YOU
AHEAD**



High efficiency indexable insert drill

MagicDrill **DRV**

Economical inserts with 4 cutting edges. Excellent chip evacuation with 6D maximum deep-hole drilling. High speed and highly efficient machining available with the combination of CVD (outer edge) and PVD (inner edge) inserts

1 Excellent drilling precision with less variation in cutting diameter Up to 6D drilling capabilities with a low cutting force design

Optimal web thickness reduces chattering with a low cutting force design

Web thickness comparison
(In-house evaluation)

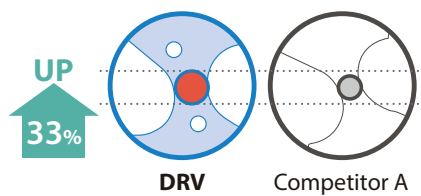

Comparison of cutting diameter variation
(In-house evaluation)

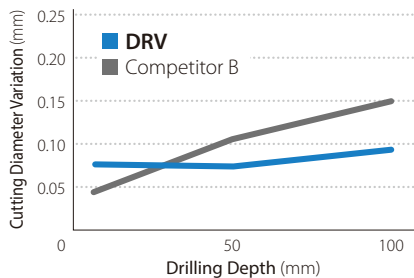

Cutting conditions: $V_c = 150$ m/min., $f = 0.06$ mm/rev.
Cutting diameter $\varnothing 20$ mm (5D), wet. Workpiece: C50.

Cutting force comparison
(In-house evaluation)

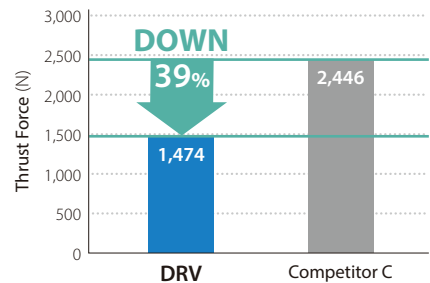

Cutting conditions: $V_c = 200$ m/min., $f = 0.12$ mm/rev.
Cutting diameter $\varnothing 20$ mm (3D), wet. Workpiece: C50.

2 Unique insert design to control chip flow

Outer edge Smooth chip evacuation with compact chips

Unique insert pattern to differentiate between outside and inside inserts

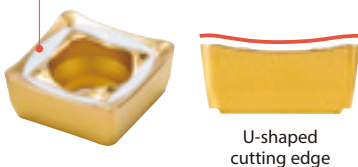

Chip shape comparison of outer insert cutting edge
(In-house evaluation)



Cutting conditions: $V_c = 150$ m/min., $f = 0.06$ mm/rev. Cutting diameter $\varnothing 20$ mm (3D), wet. Workpiece: C50.

Inner edge Excellent chip evacuation with 6D maximum deep-hole drilling

Weight per unit of length for chips generated by the inner edge
(In-house evaluation)



DRV
80 mg/mm.

Competitor E
151 mg/mm.



Pitch comparison of chips generated by the inner edge
(In-house evaluation)

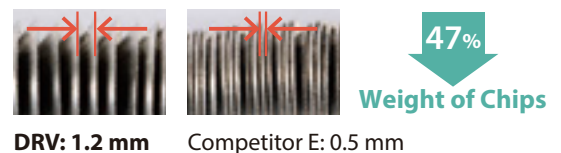

Cutting conditions: $V_c = 250$ m/min., $f = 0.08$ mm/rev. Cutting diameter $\varnothing 20$ mm (5D), wet. Workpiece: X5CrNi1810

3 CVD insert on the outer edge for highly efficient machining

High speed and highly efficient machining available with the combination of CVD (outer edge) and PVD (inner edge) inserts

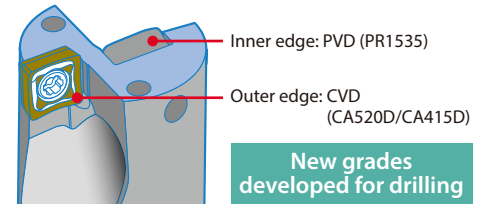

Recommended cutting conditions (Maximum value)

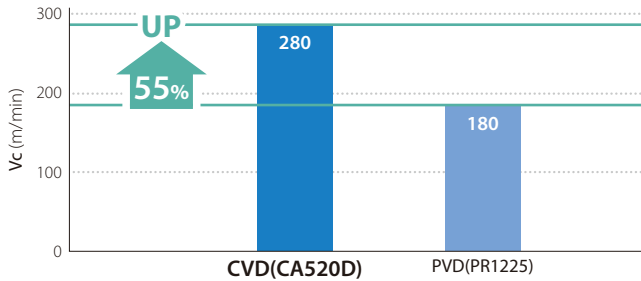

Cutting diameter Ø20 mm (3D). Workpiece: C50.

Wear resistance comparison (In-house evaluation)

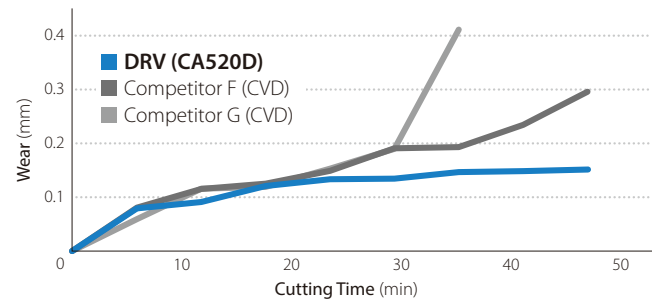

Cutting conditions: Vc = 200 m/min., f = 0.12 mm/rev. Cutting diameter Ø20 mm (3D), wet. Workpiece: 42CrMo4.

4 Economical 4-edge inserts 4 types of chipbreakers for various machining applications

Chipbreaker selection chart → Page 4

General purpose GM chipbreaker

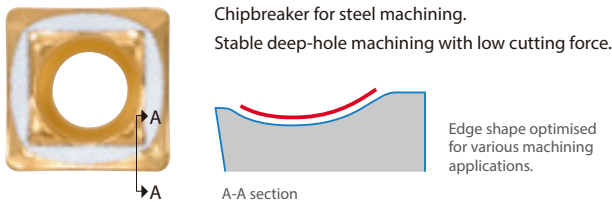

Tough edge GH chipbreaker

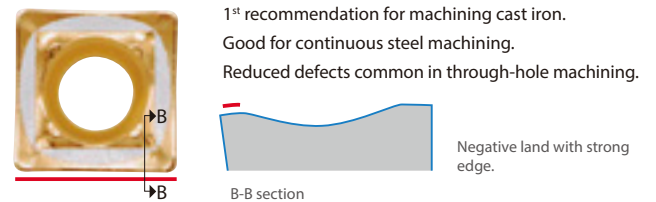

For Machining soft steel and SS material XM Chipbreaker

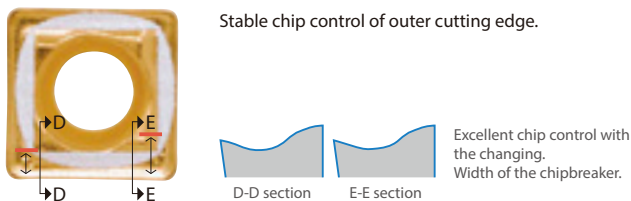

Chip control comparison (In-house evaluation)



Cutting conditions: Vc = 200 m/min., f = 0.12 mm/rev. Cutting diameter Ø16 mm (3D). Drilling depth 48 mm. Wet. Workpiece: X5CrNi1810.

SM chipbreaker for stainless steel and aluminium alloy machining

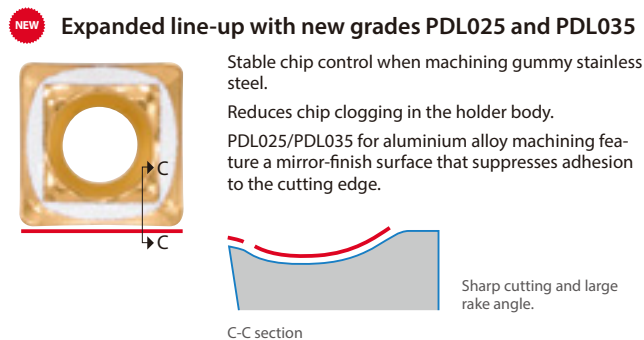

Chip control comparison (In-house evaluation)

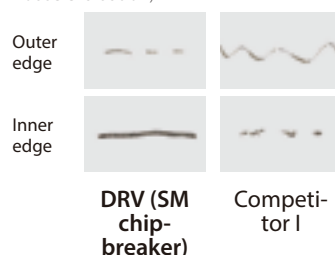

Cutting conditions: Vc = 100 m/min., f = 0.1 mm/rev. Cutting diameter Ø20 mm (3D). Drilling depth 60 mm, wet. Workpiece: ST44-2.

Comparison of remaining chips (in-house evaluation)

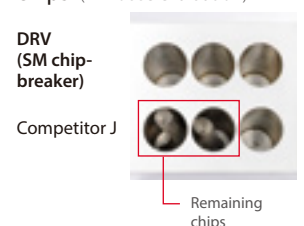

Cutting conditions: Vc = 150 m/min., f = 0.08 mm/rev. Cutting diameter Ø25 mm (5D), drilling depth 98 mm. Wet. Workpiece: X5CrNi1810.

5

Introducing new grades PDL025/PDL035 for aluminium alloy machining

The low-resistance SM chipbreaker features micro-honing and a mirror-finished rake face, reducing material adhesion on the cutting edge and improving chip control

DLC coating improves resistance to material adhesion

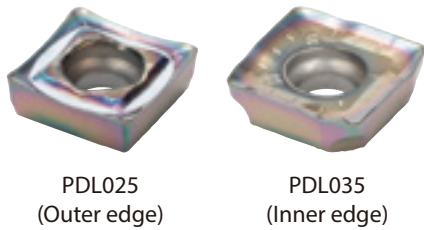

Chip control Comparison (In-house evaluation)

f (mm/rev)	0.08	0.10	0.12	0.14
DRV				
Competitor K			Interrupted machining 	Interrupted machining

Cutting conditions: Vc = 300 m/min., f = 0.08 – 0.14 mm/rev. Cutting diameter Ø20 mm (5D). Drilling depth 100 mm. Wet. Workpiece: AW-5052

Coating properties (In-house evaluation)

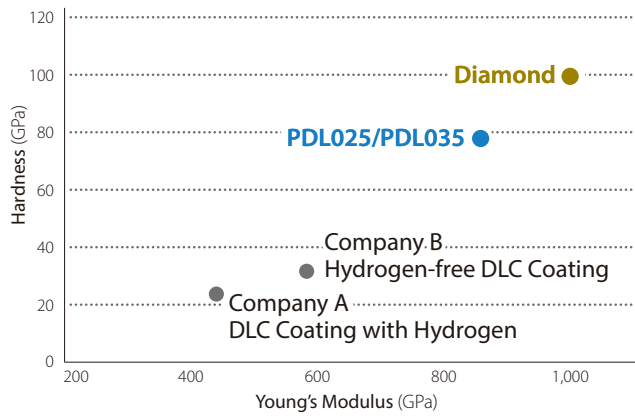

Our proprietary hydrogen-free DLC coating achieves hardness approaching diamond, enabling long tool life in aluminium alloy machining.

Excellent anti-adhesion performance enables superior surface finish quality.

Chipbreaker selection chart

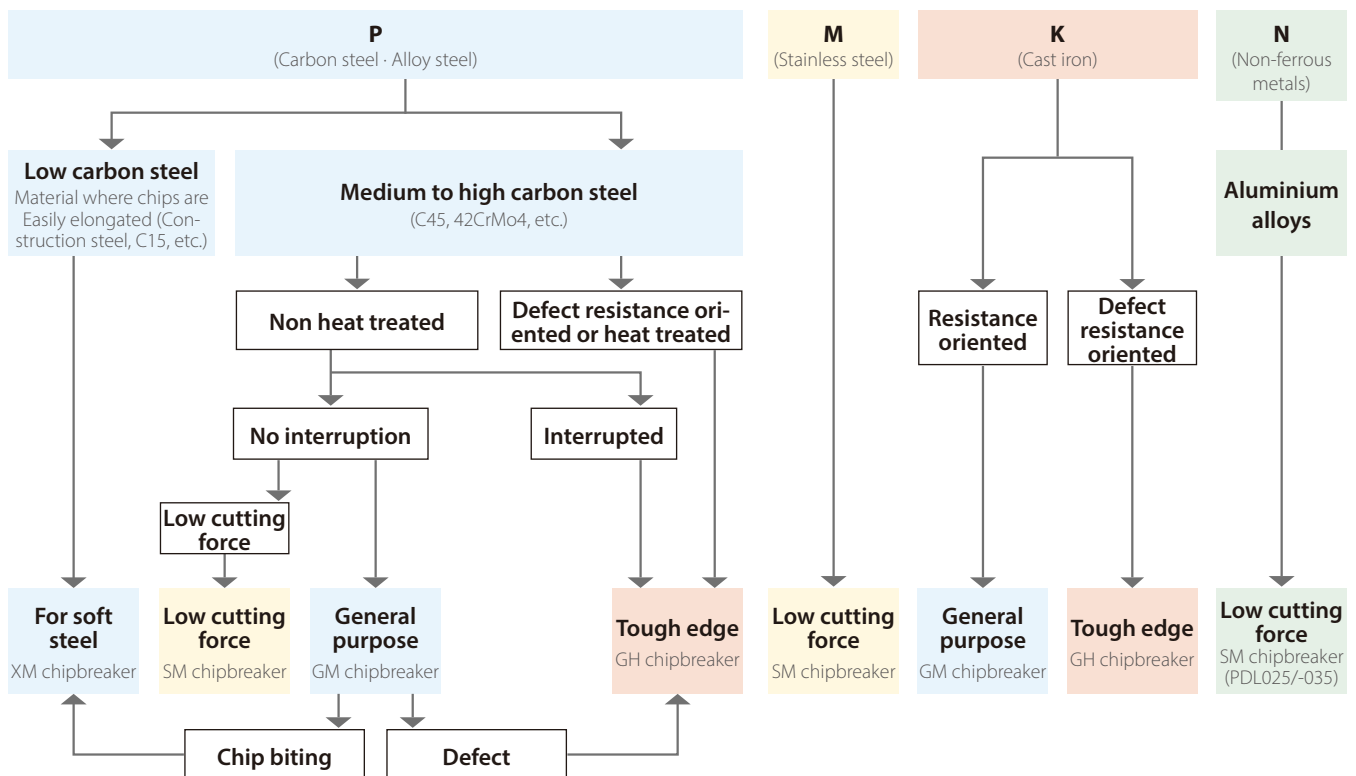

Case studies

Housing • 20CrMo5

Vc = 125 m/min. (n = 1,660 min⁻¹)
 f = 0.08 mm/rev. (Vf = 133 mm/min.)
 Drilling depth: 45 mm
 Wet (External coolant)
 S25-DRV240M-4-07
 SCMT070305GM-E PR1225
 SCMT070310GM-I PR1535

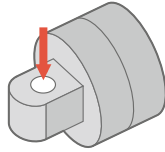

Cutting Time

DRV (ø24-4D) 16 sec

50%
or More
Cutting Time

Competitor L
(ø24-4D)

35 sec

Chattering and chip biting occurred in low rigidity work-piece of Competitor L. Speed was reduced to Vc = 60 m/min. DRV finely divided chips for stable machining at Vc = 125 m/min. (User evaluation)

Nipple • C20+Pb (Free cutting steel)

Vc = 230 m/min. (n = 3,330 min⁻¹)
 f = 0.13 mm/rev. (Vf = 433 mm/min.)
 Drilling depth: 60 mm(4D)
 30 mm(2D)
 Wet (Internal coolant)
 S25-DRV220M-4-06 (4D)
 S25-DRV220M-2-06 (2D)
 SCMT060205-GM-E PR1225
 SCMT060210-GM-I PR1535

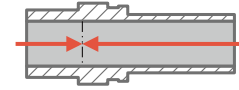

Process2
Drilling Depth 30 mm
(2D)

Process1
Drilling Depth 60 mm
(4D)

Cutting Time

DRV (ø24-4D/2D) 12 sec

40%
Cutting Time

Competitor M
(ø22-4D/2D)

20 sec

Chattering and deflection occurred with Competitor M. DRV showed stable machining and a shorter cutting time even when the cutting conditions were increased to 1.6 times or more. (User evaluation)

Valve Body • ST44-2

Vc = 220 m/min. (n = 3,200 min⁻¹)
 f = 0.05 mm/rev. (Vf = 160 mm/min.)
 Cutting depths: 50 mm
 (Blind hole/Through-hole)
 Wet (Internal coolant)
 S25-DRV220M-5-06
 SCMT060205-GM-E PR1225
 SCMT060210-GM-I PR1535

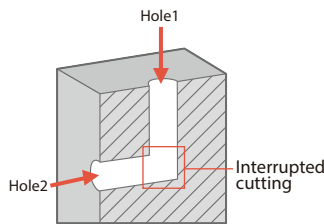

Cutting Time

DRV (ø22-5D) 14 sec

30%
or More
Cutting Time

Competitor N
(ø22-5D)

22 sec

Competitor N: Chattering occurred in the continuous part and then vibration was bigger in the crossed-hole.

DRV: There was no chattering even when increasing cutting speed and there was low vibration in the crossed-hole. The DRV achieved 1.5 times machining efficiency. (User evaluation)

Piston • 42CrMo4

Vc = 250 m/min. (n = 3,185 min⁻¹)
 f = 0.09 mm/rev. (Vf = 290 mm/min.)
 Cutting depths: 70 mm (Blind hole)
 Wet (Internal coolant)
 S25-DRV250M-4-07
 SCMT070305-GM-E CA520D
 SCMT070310-GM-I PR1535

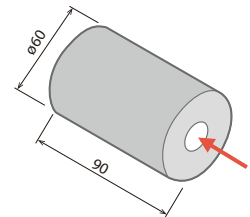

Cutting Time

DRV (ø25-4D) 14 sec

25%
Cutting Time

Competitor O
(ø25-4D)

19 sec

Competitor O: Loud chattering noise occurred.

DRV: Maintained stable machining.

No chattering even at 1.5 times faster cutting speed.

(User evaluation)

DRV holder

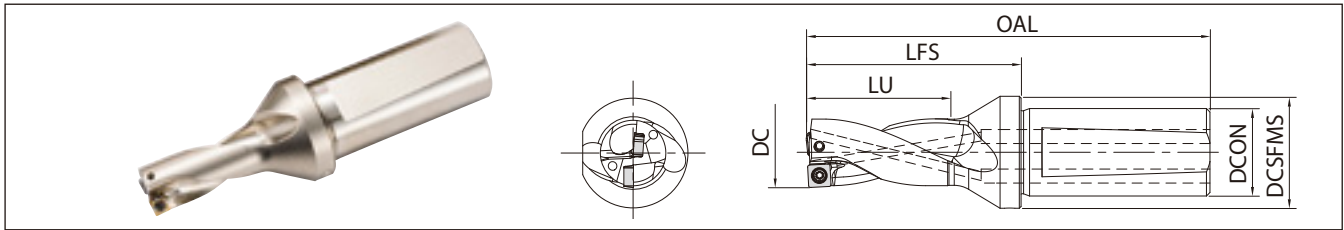

Toolholder dimensions

2D

(Drilling depth: 2×DC)

Description	Availability	No of inserts	Dimensions (mm)						Max. radial offset (mm)	Spare parts		Applicable inserts
			DC	OAL	LFS	LU	DCON	DCSFMS		Clamp screw	Wrench	
S20- DRV120M-2-03	●	2	12	82	39	24	20	27	+0.25	SB-2037TRP	FTP-6	Outer Edge LCMT030203-□□-E Inner Edge LCMT030205-□□-I
DRV125M-2-03	●		12.5	83	40	25			+0.20			
DRV130M-2-03	●		13	84	41	26			+0.15			
DRV135M-2-03	●		13.5	85	42	27			+0.10			
S20- DRV140M-2-04	●	2	14	92	49	28	20	27	+0.40	SB-2037TRP	FTP-6	Outer Edge SCMT040205-□□-E Inner Edge SCMT040209-□□-I
DRV145M-2-04	●		14.5	93	50	29			+0.35			
DRV150M-2-04	●		15	94	51	30			+0.30			
DRV155M-2-04	●		15.5	95	52	31			+0.25			
S25- DRV160M-2-05	●	2	16	110	56	32	25	32	+0.40	SB-2041TRP	FTP-6	Outer Edge SCMT050205-□□-E Inner Edge SCMT050210-□□-I
DRV165M-2-05	●		16.5	111	57	33			+0.35			
DRV170M-2-05	●		17	112	58	34			+0.30			
DRV175M-2-05	●		17.5	113	59	35			+0.25			
DRV180M-2-05	●		18	114	60	36			+0.20			
DRV185M-2-05	●		18.5	115	61	37			+0.15			
S25- DRV190M-2-06	●	2	19	113	59	38	25	32	+0.65	SB-2555TRP	DTPM-8	Outer Edge SCMT060205-□□-E Inner Edge SCMT060210-□□-I
DRV195M-2-06	●		19.5	114	60	39			+0.60			
DRV200M-2-06	●		20	115	61	40			+0.55			
DRV205M-2-06	●		20.5	116	62	41			+0.50			
DRV210M-2-06	●		21	117	63	42			+0.45			
DRV215M-2-06	●		21.5	118	64	43			+0.35			
DRV220M-2-06	●		22	119	65	44			+0.30			
S25- DRV225M-2-07	●	2	22.5	120	66	45	25	32	+0.90	SB-3060TRP	DTPM-10	Outer Edge SCMT070305-□□-E Inner Edge SCMT070310-□□-I
DRV230M-2-07	●		23	121	67	46			+0.80			
DRV235M-2-07	●		23.5	122	68	47			+0.75			
DRV240M-2-07	●		24	123	69	48			+0.70			
DRV245M-2-07	●		24.5	124	70	49			+0.65			
DRV250M-2-07	●		25	125	71	50			+0.60			
DRV255M-2-07	●		25.5	126	72	51			+0.50			
DRV260M-2-07	●		26	127	73	52			+0.45			
S32- DRV270M-2-09	●	2	27	136	77	54	32	41	+1.05	SB-3573TRP	DTPM-10	Outer Edge SCMT090405-□□-E Inner Edge SCMT090410-□□-I
DRV280M-2-09	●		28	138	79	56			+0.95			
DRV290M-2-09	●		29	140	81	58			+0.85			
DRV300M-2-09	●		30	142	83	60			+0.75			
DRV310M-2-09	●		31	144	85	62			+0.60			
DRV320M-2-09	●		32	146	87	64			+0.50			

· When offset drilling, reduce feed rate to 0.08 mm/rev. or less.
· See page 22 for adjustable sleeve (SHE).

● : Available

DRV holder

Toolholder dimensions 2D

(Drilling depth: 2xDC)

Description	Availability	No. of inserts	Dimensions (mm)						Max. radial offset (mm)	Spare parts		Applicable inserts
			DC	OAL	LFS	LU	DCON	DCSFMS		Clamp screw	Wrench	
S40- DRV330M-2-11	●	2	33	161	92	66	40	49	+1.25	SB-4086TRP	DTPM-15	Outer Edge SCMT110406-□□-E Inner Edge SCMT110410-□□-I
DRV340M-2-11	●		34	163	94	68			+1.15			
DRV350M-2-11	●		35	165	96	70			+1.00			
DRV360M-2-11	●		36	167	98	72			+0.90			
DRV370M-2-11	●		37	169	100	74			+0.80			
DRV380M-2-11	●		38	171	102	76			+0.65			
DRV390M-2-11	●		39	173	104	78			+0.55			
S40- DRV400M-2-14	●	2	40	181	112	80	40	49	+1.75	SB-50120TRPH	TTP-20	Outer Edge SCMT140508-□□-E Inner Edge SCMT140510-□□-I
DRV410M-2-14	●		41	183	114	82			+1.60			
DRV420M-2-14	●		42	185	116	84			+1.50			
DRV430M-2-14	●		43	187	118	86			+1.40			
DRV440M-2-14	●		44	189	120	88			+1.30			
DRV450M-2-14	●		45	191	122	90			+1.15			
DRV460M-2-14	●		46	193	124	92	54	+1.05				
DRV470M-2-14	●		47	195	126	94		+0.95				
DRV480M-2-14	●		48	197	128	96		+0.80				
DRV490M-2-14	●		49	199	130	98		+0.70				
S40- DRV500M-2-17	●	2	50	198	129	100	40	59	+2.10	SB-60130TRP	TTP-20	Outer Edge SCMT170608-□□-E Inner Edge SCMT170610-□□-I
DRV510M-2-17	●		51	200	131	102			+1.95			
DRV520M-2-17	●		52	202	133	104			+1.85			
DRV530M-2-17	●		53	204	135	106			+1.75			
DRV540M-2-17	●		54	206	137	108			+1.65			
DRV550M-2-17	●		55	208	139	110			+1.50			
DRV560M-2-17	●		56	210	141	112	64	+1.40				
DRV570M-2-17	●		57	212	143	114		+1.30				
DRV580M-2-17	●		58	214	145	116		+1.15				
DRV590M-2-17	●		59	216	147	118		+1.05				
DRV600M-2-17	●		60	218	149	120		+0.95				

· When offset drilling, reduce feed rate to 0.08 mm/rev. or less.
· See page 22 for adjustable sleeve (SHE).

● : Available

■ Estimated cutting tolerance (2D)

DC	Estimated cutting tolerance (mm)
Ø12 – 60 mm	+0.30 0

The above values are estimates.
These values may change due to machine, workpiece, clamping power, and cutting conditions.

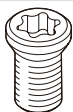
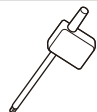
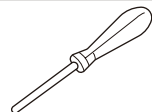
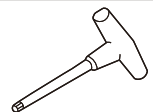
Spare parts			
Clamp screw		Wrench	
SB-···TRP(H)	FTP-6	DTPM-··	TTP-20
			

DRV holder

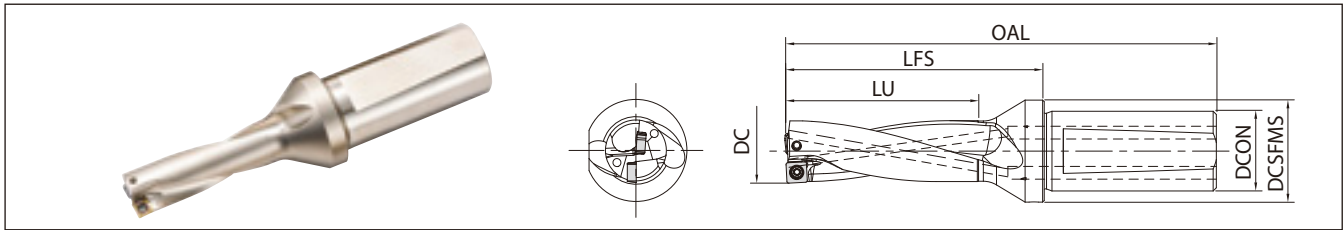

Toolholder dimensions

3D

(Drilling depth: 3×DC)

Description	Availability	No of inserts	Dimensions (mm)						Max. radial offset (Mm)	Spare parts		Applicable inserts
			DC	OAL	LFS	LU	DCON	DCSFMS		Clamp screw	Wrench	
S20- DRV120M-3-03	●	2	12	94	51	36	20	27	+0.25	SB-2037TRP	FTP-6	Outer Edge LCMT030203-□□-E Inner Edge LCMT030205-□□-I
DRV125M-3-03	●		12.5	96	53	37.5			+0.20			
DRV130M-3-03	●		13	97	54	39			+0.15			
DRV135M-3-03	●		13.5	99	56	40.5			+0.10			
S20- DRV140M-3-04	●	2	14	106	63	42	20	27	+0.40	SB-2037TRP	FTP-6	Outer Edge SCMT040205-□□-E Inner Edge SCMT040209-□□-I
DRV145M-3-04	●		14.5	108	65	43.5			+0.35			
DRV150M-3-04	●		15	109	66	45			+0.30			
DRV155M-3-04	●		15.5	111	68	46.5			+0.25			
S25- DRV160M-3-05	●	2	16	126	72	48	25	32	+0.40	SB-2041TRP	FTP-6	Outer Edge SCMT050205-□□-E Inner Edge SCMT050210-□□-I
DRV165M-3-05	●		16.5	127	73	49.5			+0.35			
DRV170M-3-05	●		17	129	75	51			+0.30			
DRV175M-3-05	●		17.5	130	76	52.5			+0.25			
DRV180M-3-05	●		18	132	78	54			+0.20			
DRV185M-3-05	●		18.5	133	79	55.5			+0.15			
S25- DRV190M-3-06	●	2	19	132	78	57	25	32	+0.65	SB-2555TRP	DTPM-8	Outer Edge SCMT060205-□□-E Inner Edge SCMT060210-□□-I
DRV195M-3-06	●		19.5	134	80	58.5			+0.60			
DRV200M-3-06	●		20	135	81	60			+0.55			
DRV205M-3-06	●		20.5	137	83	61.5			+0.50			
DRV210M-3-06	●		21	138	84	63			+0.45			
DRV215M-3-06	●		21.5	140	86	64.5			+0.35			
DRV220M-3-06	●		22	141	87	66			+0.30			
S25- DRV225M-3-07	●	2	22.5	142	88	67.5	25	32	+0.90	SB-3060TRP	DTPM-10	Outer Edge SCMT070305-□□-E Inner Edge SCMT070310-□□-I
DRV230M-3-07	●		23	144	90	69			+0.80			
DRV235M-3-07	●		23.5	145	91	70.5			+0.75			
DRV240M-3-07	●		24	147	93	72			+0.70			
DRV245M-3-07	●		24.5	148	94	73.5			+0.65			
DRV250M-3-07	●		25	150	96	75			+0.60			
DRV255M-3-07	●		25.5	151	97	76.5			+0.50			
DRV260M-3-07	●		26	153	99	78			+0.45			
S32- DRV265M-3-09	●	2	26.5	161	102	79.5	32	41	+1.15	SB-3573TRP	DTPM-10	Outer Edge SCMT090405-□□-E Inner Edge SCMT090410-□□-I
DRV270M-3-09	●		27	163	104	81			+1.05			
DRV275M-3-09	●		27.5	164	105	82.5			+1.00			
DRV280M-3-09	●		28	166	107	84			+0.95			
DRV285M-3-09	●		28.5	167	108	85.5			+0.90			
DRV290M-3-09	●		29	169	110	87			+0.85			
DRV295M-3-09	●		29.5	170	111	88.5			+0.80			
DRV300M-3-09	●		30	172	113	90			+0.75			
DRV305M-3-09	●		30.5	173	114	91.5			+0.65			
DRV310M-3-09	●		31	175	116	93			+0.60			
DRV315M-3-09	●		31.5	176	117	94.5			+0.55			
DRV320M-3-09	●		32	178	119	96			+0.50			

· When offset drilling, reduce feed rate to 0.08 mm/rev. or less.
· See page 22 for adjustable sleeve (SHE).

● : Available

DRV holder

Toolholder dimensions

3D

(Drilling depth: 3×DC)

Description	Availability	No. of Inserts	Dimensions (mm)						Max. radial offset (Mm)	Spare parts		Applicable inserts
			DC	OAL	LFS	LU	DCON	DCSFMS		Clamp screw	Wrench	
S40- DRV330M-3-11	●	2	33	194	125	99	40	49	+1.25	SB-4086TRP	DTPM-15	Outer Edge SCMT110406-□□-E Inner Edge SCMT110410-□□-I
DRV340M-3-11	●		34	197	128	102			+1.15			
DRV350M-3-11	●		35	200	131	105			+1.00			
DRV360M-3-11	●		36	203	134	108			+0.90			
DRV370M-3-11	●		37	206	137	111			+0.80			
DRV380M-3-11	●		38	209	140	114			+0.65			
DRV390M-3-11	●		39	212	143	117			+0.55			
S40- DRV400M-3-14	●	2	40	221	152	120	40	49	+1.75	SB-50120TRPH	TTP-20	Outer Edge SCMT140508-□□-E Inner Edge SCMT140510-□□-I
DRV410M-3-14	●		41	224	155	123			+1.60			
DRV420M-3-14	●		42	227	158	126			+1.50			
DRV430M-3-14	●		43	230	161	129			+1.40			
DRV440M-3-14	●		44	233	164	132			+1.30			
DRV450M-3-14	●		45	236	167	135			+1.15			
DRV460M-3-14	●		46	239	170	138	54	+1.05				
DRV470M-3-14	●		47	242	173	141		+0.95				
DRV480M-3-14	●		48	245	176	144		+0.80				
DRV490M-3-14	●		49	248	179	147		+0.70				
S40- DRV500M-3-17	●	2	50	248	179	150	40	59	+2.10	SB-60130TRP	TTP-20	Outer Edge SCMT170608-□□-E Inner Edge SCMT170610-□□-I
DRV510M-3-17	●		51	251	182	153			+1.95			
DRV520M-3-17	●		52	254	185	156			+1.85			
DRV530M-3-17	●		53	257	188	159			+1.75			
DRV540M-3-17	●		54	260	191	162			+1.65			
DRV550M-3-17	●		55	263	194	165			+1.50			
DRV560M-3-17	●		56	266	197	168	+1.40	64	+1.30			
DRV570M-3-17	●		57	269	200	171	+1.15					
DRV580M-3-17	●		58	272	203	174	+1.05					
DRV590M-3-17	●		59	275	206	177	+1.05					
DRV600M-3-17	●		60	278	209	180	+0.95					

· When offset drilling, reduce feed rate to 0.08 mm/rev. or less.
· See page 22 for adjustable sleeve (SHE).

● : Available

■ Estimated cutting tolerance (3D)

DC	Estimated cutting tolerance (mm)
Ø12 – 60 mm	+0.30 0

The above values are estimates.
These values may change due to machine, workpiece, clamping power, and cutting conditions.

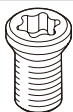
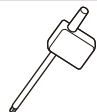
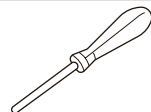
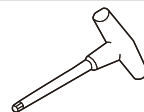
Spare parts			
Clamp screw		Wrench	
SB-···TRP(H)	FTP-6	DTPM-···	TTP-20
			

DRV holder

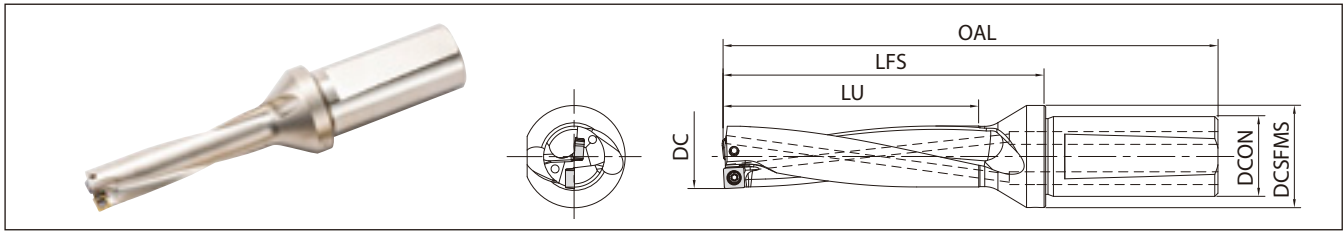

Toolholder dimensions

4D

(Drilling depth: 4×DC)

Description	Availability	No. of inserts	Dimensions (mm)						Max. radial offset (mm)	Spare parts		Applicable inserts
			DC	OAL	LFS	LU	DCON	DCSFMS		Clamp screw	Wrench	
S20- DRV120M-4-03	●	2	12	106	63	48	20	27	+0.25	SB-2037TRP	FTP-6	Outer Edge LCMT030203-□□-E Inner Edge LCMT030205-□□-I
DRV125M-4-03	●		12.5	108	65	50			+0.20			
DRV130M-4-03	●		13	110	67	52			+0.15			
DRV135M-4-03	●		13.5	112	69	54			+0.10			
S20- DRV140M-4-04	●	2	14	120	77	56	20	27	+0.40	SB-2037TRP	FTP-6	Outer Edge SCMT040205-□□-E Inner Edge SCMT040209-□□-I
DRV145M-4-04	●		14.5	122	79	58			+0.35			
DRV150M-4-04	●		15	124	81	60			+0.30			
DRV155M-4-04	●		15.5	126	83	62			+0.25			
S25- DRV160M-4-05	●	2	16	142	88	64	25	32	+0.40	SB-2041TRP	FTP-6	Outer Edge SCMT050205-□□-E Inner Edge SCMT050210-□□-I
DRV165M-4-05	●		16.5	144	90	66			+0.35			
DRV170M-4-05	●		17	146	92	68			+0.30			
DRV175M-4-05	●		17.5	148	94	70			+0.25			
DRV180M-4-05	●		18	150	96	72			+0.20			
DRV185M-4-05	●		18.5	152	98	74			+0.15			
S25- DRV190M-4-06	●	2	19	151	97	76	25	32	+0.65	SB-2555TRP	DTPM-8	Outer Edge SCMT060205-□□-E Inner Edge SCMT060210-□□-I
DRV195M-4-06	●		19.5	153	99	78			+0.60			
DRV200M-4-06	●		20	155	101	80			+0.55			
DRV205M-4-06	●		20.5	157	103	82			+0.50			
DRV210M-4-06	●		21	159	105	84			+0.45			
DRV215M-4-06	●		21.5	161	107	86			+0.35			
DRV220M-4-06	●		22	163	109	88			+0.30			
S25- DRV225M-4-07	●	2	22.5	165	111	90	25	32	+0.90	SB-3060TRP	DTPM-10	Outer Edge SCMT070305-□□-E Inner Edge SCMT070310-□□-I
DRV230M-4-07	●		23	167	113	92			+0.80			
DRV235M-4-07	●		23.5	169	115	94			+0.75			
DRV240M-4-07	●		24	171	117	96			+0.70			
DRV245M-4-07	●		24.5	173	119	98			+0.65			
DRV250M-4-07	●		25	175	121	100			+0.60			
DRV255M-4-07	●		25.5	177	123	102			+0.50			
DRV260M-4-07	●		26	179	125	104			+0.45			
S32- DRV270M-4-09	●	2	27	190	131	108	32	41	+1.05	SB-3573TRP	DTPM-10	Outer Edge SCMT090405-□□-E Inner Edge SCMT090410-□□-I
DRV280M-4-09	●		28	194	135	112			+0.95			
DRV290M-4-09	●		29	198	139	116			+0.85			
DRV300M-4-09	●		30	202	143	120			+0.75			
DRV310M-4-09	●		31	206	147	124			+0.60			
DRV320M-4-09	●		32	210	151	128			+0.50			

- When offset drilling, reduce feed rate to 0.06 mm/rev. or less.
- See page 22 for adjustable sleeve (SHE).

● : Available

DRV holder

Toolholder dimensions

4D

(Drilling depth: 4×DC)

Description	Availability	No. of inserts	Dimensions (mm)						Max. radial offset (mm)	Spare parts		Applicable inserts
			DC	OAL	LFS	LU	DCON	DCSFMS		Clamp screw	Wrench	
S40- DRV330M-4-11	●	2	33	227	158	132	40	49	+1.25	SB-4086TRP	DTPM-15	Outer Edge SCMT110406-□□-E Inner Edge SCMT110410-□□-I
DRV340M-4-11	●		34	231	162	136			+1.15			
DRV350M-4-11	●		35	235	166	140			+1.00			
DRV360M-4-11	●		36	239	170	144			+0.90			
DRV370M-4-11	●		37	243	174	148			+0.80			
DRV380M-4-11	●		38	247	178	152			+0.65			
DRV390M-4-11	●		39	251	182	156			+0.55			
S40- DRV400M-4-14	●	2	40	261	192	160	40	49	+1.75	SB-50120TRPH	TTP-20	Outer Edge SCMT140508-□□-E Inner Edge SCMT140510-□□-I
DRV410M-4-14	●		41	265	196	164			+1.60			
DRV420M-4-14	●		42	269	200	168			+1.50			
DRV430M-4-14	●		43	273	204	172			+1.40			
DRV440M-4-14	●		44	277	208	176		+1.30				
DRV450M-4-14	●		45	281	212	180		+1.15				
DRV460M-4-14	●		46	285	216	184		+1.05				
DRV470M-4-14	●	47	289	220	188	+0.95						
S50- DRV480M-4-14	●	2	48	293	224	192	50	59	+0.80	SB-60130TRP	TTP-20	Outer Edge SCMT170608-□□-E Inner Edge SCMT170610-□□-I
DRV490M-4-14	●		49	297	228	196			+0.70			
S50- DRV500M-4-17	●	2	50	298	229	200	50	59	+2.10	SB-60130TRP	TTP-20	Outer Edge SCMT170608-□□-E Inner Edge SCMT170610-□□-I
DRV510M-4-17	●		51	302	233	204			+1.95			
DRV520M-4-17	●		52	306	237	208			+1.85			
DRV530M-4-17	●		53	310	241	212			+1.75			
DRV540M-4-17	●		54	314	245	216			+1.65			
DRV550M-4-17	●		55	318	249	220			+1.50			
DRV560M-4-17	●		56	322	253	224	+1.40					
DRV570M-4-17	●		57	326	257	228	+1.30					
DRV580M-4-17	●		58	330	261	232	+1.15					
DRV590M-4-17	●		59	334	265	236	+1.05					
DRV600M-4-17	●		60	338	269	240	+0.95					

· When offset drilling, reduce feed rate to 0.06 mm/rev. or less.
· See page 22 for adjustable sleeve (SHE).

● : Available

■ Estimated cutting tolerance (4D)

DC	Estimated cutting tolerance (mm)
Ø12 – 39 mm	+0.35 0
Ø40 – 60 mm	+0.40 0

The above values are estimates.
These values may change due to machine, workpiece, clamping power, and cutting conditions.

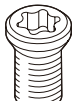
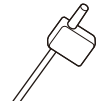
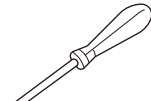
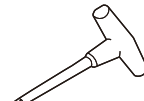
Spare parts			
Clamp screw	Wrench		
SB-··TRP(H)	FTP-6	DTPM-··	TTP-20
			

DRV holder

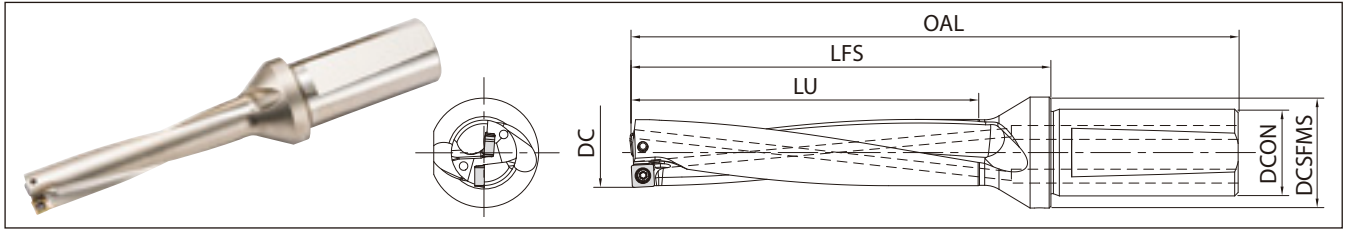

Toolholder dimensions 5D

(Drilling depth: 5×DC)

Description	Availability	No. of inserts	Dimensions (mm)						Max. radial offset (mm)	Spare parts		Applicable inserts
			DC	OAL	LFS	LU	DCON	DCSFMS		Clamp screw	Wrench	
S20- DRV120M-5-03	●	2	12	118	75	60	20	27	+0.25	SB-2037TRP	FTP-6	Outer Edge LCMT030203-□□-E Inner Edge LCMT030205-□□-I
DRV130M-5-03	●		13	123	80	65			+0.15			
S20- DRV140M-5-04	●	2	14	134	91	70	20	27	+0.40	SB-2037TRP	FTP-6	Outer Edge SCMT040205-□□-E Inner Edge SCMT040209-□□-I
DRV150M-5-04	●		15	139	96	75			+0.30			
S25- DRV160M-5-05	●	2	16	158	104	80	25	32	+0.40	SB-2041TRP	FTP-6	Outer Edge SCMT050205-□□-E Inner Edge SCMT050210-□□-I
DRV170M-5-05	●		17	163	109	85			+0.30			
DRV180M-5-05	●		18	168	114	90			+0.20			
DRV190M-5-06	●		19	170	116	95			+0.65			
S25- DRV200M-5-06	●	2	20	175	121	100	25	32	+0.55	SB-2555TRP	DTPM-8	Outer Edge SCMT060205-□□-E Inner Edge SCMT060210-□□-I
DRV210M-5-06	●		21	180	126	105			+0.45			
DRV220M-5-06	●		22	185	131	110			+0.30			
DRV230M-5-07	●		23	190	136	115			+0.80			
S25- DRV240M-5-07	●	2	24	195	141	120	25	32	+0.70	SB-3060TRP	DTPM-10	Outer Edge SCMT070305-□□-E Inner Edge SCMT070310-□□-I
DRV250M-5-07	●		25	200	146	125			+0.60			
DRV260M-5-07	●		26	205	151	130			+0.45			
DRV270M-5-09	●		27	217	158	135			+1.05			
S32- DRV280M-5-09	●	2	28	222	163	140	32	41	+0.95	SB-3573TRP	DTPM-10	Outer Edge SCMT090405-□□-E Inner Edge SCMT090410-□□-I
DRV290M-5-09	●		29	227	168	145			+0.85			
DRV300M-5-09	●		30	232	173	150			+0.75			
DRV310M-5-09	●		31	237	178	155			+0.60			
DRV320M-5-09	●		32	242	183	160			+0.50			
DRV330M-5-11	●		33	260	191	165			+1.25			
S40- DRV340M-5-11	●	2	34	265	196	170	40	49	+1.15	SB-4086TRP	DTPM-15	Outer Edge SCMT110406-□□-E Inner Edge SCMT110410-□□-I
DRV350M-5-11	●		35	270	201	175			+1.00			
DRV360M-5-11	●		36	275	206	180			+0.90			
DRV370M-5-11	●		37	280	211	185			+0.80			
DRV380M-5-11	●		38	285	216	190			+0.65			
DRV390M-5-11	●		39	290	221	195			+0.55			
S40- DRV400M-5-14	●	2	40	301	232	200	40	49	+1.75	SB-50120TRPH	TTP-20	Outer Edge SCMT140508-□□-E Inner Edge SCMT140510-□□-I
DRV410M-5-14	●		41	306	237	205			+1.60			
DRV420M-5-14	●		42	311	242	210			+1.50			
DRV430M-5-14	●		43	316	247	215			+1.40			
DRV440M-5-14	●		44	321	252	220			+1.30			
DRV450M-5-14	●		45	326	257	225			+1.15			
DRV460M-5-14	●		46	331	262	230			+1.05			
DRV470M-5-14	●		47	336	267	235			+0.95			
S50- DRV480M-5-14	●	2	48	341	272	240	50	59	+0.80	SB-60130TRP	TTP-20	Outer Edge SCMT170608-□□-E Inner Edge SCMT170610-□□-I
DRV490M-5-14	●		49	346	277	245			+0.70			
S50- DRV500M-5-17	●	2	50	348	279	250	50	59	+2.10	SB-60130TRP	TTP-20	Outer Edge SCMT170608-□□-E Inner Edge SCMT170610-□□-I
DRV510M-5-17	●		51	353	284	255			+1.95			
DRV520M-5-17	●		52	358	289	260			+1.85			
DRV530M-5-17	●		53	363	294	265			+1.75			
DRV540M-5-17	●		54	368	299	270			+1.65			
DRV550M-5-17	●		55	373	304	275			+1.50			
DRV560M-5-17	●		56	378	309	280			+1.40			
DRV570M-5-17	●		57	383	314	285			+1.30			
DRV580M-5-17	●		58	388	319	290			+1.15			
DRV590M-5-17	●		59	393	324	295			+1.05			
DRV600M-5-17	●	60	398	329	300	+0.95						

When offset drilling, reduce feed rate to 0.05 mm/rev. or less. See page 22 for adjustable sleeve (SHE).

● : Available

Estimated cutting tolerance (5D)

DC	Estimated cutting tolerance (mm)
Ø12 – 39 mm	+0.35 0
Ø40 – 60 mm	+0.40 0

The above values are estimates.
These values may change due to machine, workpiece, clamping power, and cutting conditions.

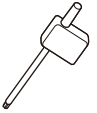
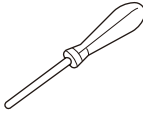
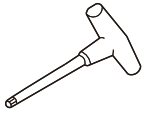
Spare parts			
Clamp screw	FTP-6	Wrench	TTP-20
SB-··TRP(H)		DTPM-··	
			

DRV holder

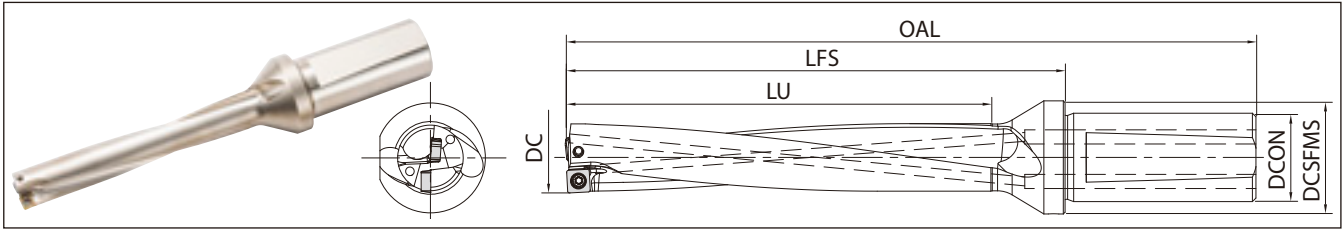

Toolholder dimensions

6D

(Drilling depth: 6×DC)

Description	Availability	No. of inserts	Dimensions (mm)						Max. radial offset (Mm)	Spare parts		Applicable inserts
			DC	OAL	LFS	LU	DCON	DCSFMS		Clamp screw	Wrench	
S20- DRV120M-6-03 DRV130M-6-03	●	2	12	130	87	72	20	27	+0.25	SB-2037TRP	FTP-6	Outer Edge LCMT030203-□□-E Inner Edge LCMT030205-□□-I
	●		13	136	93	78			+0.15			
S20- DRV140M-6-04 DRV150M-6-04	●	2	14	148	105	84	20	27	+0.40	SB-2037TRP	FTP-6	Outer Edge SCMT040205-□□-E Inner Edge SCMT040209-□□-I
	●		15	154	111	90			+0.30			
S25- DRV160M-6-05 DRV170M-6-05 DRV180M-6-05	●	2	16	174	120	96	25	32	+0.40	SB-2041TRP	FTP-6	Outer Edge SCMT050205-□□-E Inner Edge SCMT050210-□□-I
	●		17	180	126	102			+0.30			
	●		18	186	132	108			+0.20			
S25- DRV190M-6-06 DRV200M-6-06 DRV210M-6-06 DRV220M-6-06	●	2	19	189	135	114	25	32	+0.65	SB-2555TRP	DTPM-8	Outer Edge SCMT060205-□□-E Inner Edge SCMT060210-□□-I
	●		20	195	141	120			+0.55			
	●		21	201	147	126			+0.45			
	●		22	207	153	132			+0.30			
S25- DRV230M-6-07 DRV240M-6-07 DRV250M-6-07 DRV260M-6-07	●	2	23	213	159	138	25	32	+0.80	SB-3060TRP	DTPM-10	Outer Edge SCMT070305-□□-E Inner Edge SCMT070310-□□-I
	●		24	219	165	144			+0.70			
	●		25	225	171	150			+0.60			
	●		26	231	177	156			+0.45			
	●		27	237	183	162			+0.35			
S32- DRV270M-6-09 DRV280M-6-09 DRV290M-6-09 DRV300M-6-09 DRV310M-6-09 DRV320M-6-09	●	2	27	244	185	162	32	41	+1.05	SB-3573TRP	DTPM-10	Outer Edge SCMT090405-□□-E Inner Edge SCMT090410-□□-I
	●		28	250	191	168			+0.95			
	●		29	256	197	174			+0.85			
	●		30	262	203	180			+0.75			
	●		31	268	209	186			+0.60			
	●		32	274	215	192			+0.50			
S40- DRV330M-6-11 DRV340M-6-11 DRV350M-6-11 DRV360M-6-11 DRV370M-6-11 DRV380M-6-11 DRV390M-6-11	●	2	33	293	224	198	40	49	+1.25	SB-4086TRP	DTPM-15	Outer Edge SCMT110406-□□-E Inner Edge SCMT110410-□□-I
	●		34	299	230	204			+1.15			
	●		35	305	236	210			+1.00			
	●		36	311	242	216			+0.90			
	●		37	317	248	222			+0.80			
	●		38	323	254	228			+0.65			
	●		39	329	260	234			+0.55			
S40- DRV400M-6-14 DRV410M-6-14 DRV420M-6-14 DRV430M-6-14 DRV440M-6-14 DRV450M-6-14	●	2	40	341	272	240	40	49	+1.75	SB-50120TRPH	TTP-20	Outer Edge SCMT140508-□□-E Inner Edge SCMT140510-□□-I
	●		41	347	278	246			+1.60			
	●		42	353	284	252			+1.50			
	●		43	359	290	258			+1.40			
	●		44	365	296	264			+1.30			
	●		45	371	302	270			+1.15			
S50- DRV500M-6-17 DRV550M-6-17 DRV600M-6-17	●	2	50	398	329	300	50	59	+2.10	SB-60130TRP	TTP-20	Outer Edge SCMT170608-□□-E Inner Edge SCMT170610-□□-I
	●		55	428	359	330			+1.50			
	●		60	458	389	360			+0.95			

· When offset drilling, reduce feed rate to 0.04 mm/rev. or less. See page 22 for adjustable sleeve (SHE).

● : Available

■ Estimated cutting tolerance (6D)

DC	Estimated cutting tolerance (mm)
Ø12 – 39 mm	+0.45
	0
Ø40 – 60 mm	+0.50
	0

The above values are estimates.
These values may change due to machine, workpiece, clamping power, and cutting conditions.

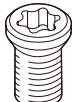
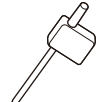
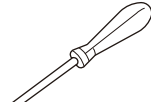
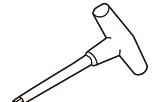
Spare parts			
Clamp screw	FTP-6	Wrench	TTP-20
SB-···TRP(H)		DTPM-··	
			









DRV insert (Outer edge)

Usage classification		P	Carbon steel - Alloy steel		☆	★						
			Mould steel						☆	★		
★ : 1 st recommendation (High speed and highly efficient machining) ☆ : 2 nd recommendation (Stable machining oriented)		M	Stainless steel		☆	★						
		K	Cast iron		☆		★					
		N	Non-ferrous metals					★				
Shape	Application	Description	Dimensions (mm)					Angle	MEGACOAT	CVD coated carbide		DLC coated carbide
			IC W1/L	S	D1	RE	AN			PR1225	CA520D	
 LCMT SCMT General purpose	Outer edge	LCMT 030203-GM-E	4.40/5.54	2.0	2.3	0.3	7°	●	●	●		
		SCMT 040205-GM-E	4.80	2.2	2.4	0.5	7°	●	●	●		
		050205-GM-E	5.25	2.6	2.4	0.5	7°	●	●	●		
		060205-GM-E	6.40	2.8	2.9	0.5	7°	●	●	●		
		070305-GM-E	7.65	3.2	3.5	0.5	7°	●	●	●		
		090405-GM-E	9.10	4.1	4.0	0.5	7°	●	●	●		
		110406-GM-E	11.00	4.5	4.6	0.6	7°	●	●	●		
		140508-GM-E	13.80	5.0	5.7	0.8	7°	●	●	●		
		170608-GM-E	16.80	6.58	6.9	0.8	7°	●	●	●		
 LCMT SCMT Tough edge	Outer edge	LCMT 030203-GH-E	4.40/5.54	2.0	2.3	0.3	7°	●	●	●		
		SCMT 040205-GH-E	4.80	2.2	2.4	0.5	7°	●	●	●		
		050205-GH-E	5.25	2.6	2.4	0.5	7°	●	●	●		
		060205-GH-E	6.40	2.8	2.9	0.5	7°	●	●	●		
		070305-GH-E	7.65	3.2	3.5	0.5	7°	●	●	●		
		090405-GH-E	9.10	4.1	4.0	0.5	7°	●	●	●		
		110406-GH-E	11.00	4.5	4.6	0.6	7°	●	●	●		
		140508-GH-E	13.80	5.0	5.7	0.8	7°	●	●	●		
		170608-GH-E	16.80	6.58	6.9	0.8	7°	●	●	●		
 For soft steel machining	Outer edge	SCMT 040205-XM-E	4.80	2.2	2.4	0.5	7°	●	●			
		050205-XM-E	5.25	2.6	2.4	0.5	7°	●	●			
		060205-XM-E	6.40	2.8	2.9	0.5	7°	●	●			
		070305-XM-E	7.65	3.2	3.5	0.5	7°	●	●			
		090405-XM-E	9.10	4.1	4.0	0.5	7°	●	●			
		110406-XM-E	11.00	4.5	4.6	0.6	7°	●	●			
		140508-XM-E	13.80	5.0	5.7	0.8	7°	●	●			
		170608-XM-E	16.80	6.58	6.9	0.8	7°	●	●			
 LCMT SCMT For machining stainless steel and aluminium alloys	Outer edge	LCMT 030203-SM-E	4.40/5.54	2.0	2.3	0.3	7°	●	●		●	
		SCMT 040205-SM-E	4.80	2.2	2.4	0.5	7°	●	●		●	
		050205-SM-E	5.25	2.6	2.4	0.5	7°	●	●		●	
		060205-SM-E	6.40	2.8	2.9	0.5	7°	●	●		●	
		070305-SM-E	7.65	3.2	3.5	0.5	7°	●	●		●	
		090405-SM-E	9.10	4.1	4.0	0.5	7°	●	●		●	
		110406-SM-E	11.00	4.5	4.6	0.6	7°	●	●		●	
		140508-SM-E	13.80	5.0	5.7	0.8	7°	●	●		●	
		170608-SM-E	16.80	6.58	6.9	0.8	7°	●	●		●	

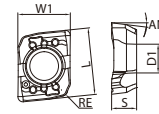
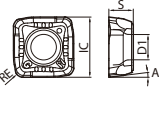
* LCMT03*** is a 2-edge insert.

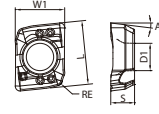
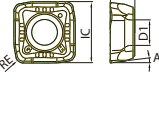
● : Available

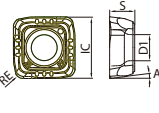
DRV insert (Inner edge)

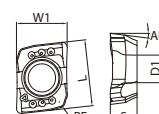
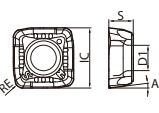
Usage classification		P	Carbon steel • Alloy steel		★					
			Mould steel		★					
★ : 1 st recommendation (High speed and highly efficient machining) ☆ : 2 nd recommendation (Stable machining oriented)		M	Stainless steel		★					
		K	Cast iron		★					
		N	Non-ferrous metals		★					
Shape	Applica-tion	Description	Dimensions (mm)					Angle	MEGACOAT NANO	DLC coated carbide
			IC W1/L	S	D1	RE	AN			
 LCMT  SCMT General Purpose	 	LCMT 030205-GM-I	4.16/5.37	2.0	2.3	0.5	7°	●		
		SCMT 040209-GM-I	5.00	2.2	2.4	0.9	7°	●		
		050210-GM-I	5.70	2.6	2.4	1.0	7°	●		
		060210-GM-I	6.90	2.8	2.9	1.0	7°	●		
		070310-GM-I	8.20	3.2	3.5	1.0	7°	●		
		090410-GM-I	9.80	4.1	4.0	1.0	7°	●		
		110410-GM-I	11.90	4.5	4.6	1.0	7°	●		
		140510-GM-I	14.90	5.0	5.7	1.0	7°	●		
		170610-GM-I	17.90	6.58	6.9	1.0	7°	●		
 LCMT  SCMT Tough Edge	 	LCMT 030205-GH-I	4.16/5.37	2.0	2.3	0.5	7°	●		
		SCMT 040209-GH-I	5.00	2.2	2.4	0.9	7°	●		
		050210-GH-I	5.70	2.6	2.4	1.0	7°	●		
		060210-GH-I	6.90	2.8	2.9	1.0	7°	●		
		070310-GH-I	8.20	3.2	3.5	1.0	7°	●		
		090410-GH-I	9.80	4.1	4.0	1.0	7°	●		
		110410-GH-I	11.90	4.5	4.6	1.0	7°	●		
		140510-GH-I	14.90	5.0	5.7	1.0	7°	●		
		170610-GH-I	17.90	6.58	6.9	1.0	7°	●		
 SCMT For Soft Steel Machining		SCMT 040209-XM-I	5.00	2.2	2.4	0.9	7°	●		
		050210-XM-I	5.70	2.6	2.4	1.0	7°	●		
		060210-XM-I	6.90	2.8	2.9	1.0	7°	●		
		070310-XM-I	8.20	3.2	3.5	1.0	7°	●		
		090410-XM-I	9.80	4.1	4.0	1.0	7°	●		
		110410-XM-I	11.90	4.5	4.6	1.0	7°	●		
		140510-XM-I	14.90	5.0	5.7	1.0	7°	●		
		170610-XM-I	17.90	6.58	6.9	1.0	7°	●		
 LCMT  SCMT For machining stainless steel and aluminium alloys	 	LCMT 030205-SM-I	4.16/5.37	2.0	2.3	0.5	7°	●	●	
		SCMT 040209-SM-I	5.00	2.2	2.4	0.9	7°	●	●	
		050210-SM-I	5.70	2.6	2.4	1.0	7°	●	●	
		060210-SM-I	6.90	2.8	2.9	1.0	7°	●	●	
		070310-SM-I	8.20	3.2	3.5	1.0	7°	●	●	
		090410-SM-I	9.80	4.1	4.0	1.0	7°	●	●	
		110410-SM-I	11.90	4.5	4.6	1.0	7°	●	●	
		140510-SM-I	14.90	5.0	5.7	1.0	7°	●	●	
		170610-SM-I	17.90	6.58	6.9	1.0	7°	●	●	

* LCMT03*** is a 2-edge insert.

● : Available

For MagicDrill DRV

Chamfering attachment

- Free-positioning according to the drilling depth
- Versatile chamfering attachment

1 High efficiency machining

Double inserts allow for increased feed rates. Low cutting force reduces chattering during increased feed rates.

2 Excellent chip evacuation

Chip flow grooves are designed to follow the flutes of the drill body delivering excellent chip evacuation.

3 High chattering resistance

Moulded chipbreaker on chamfering insert reduces cutting force. Special insert design prevents fracturing on the edge. Economical 2 edge inserts.

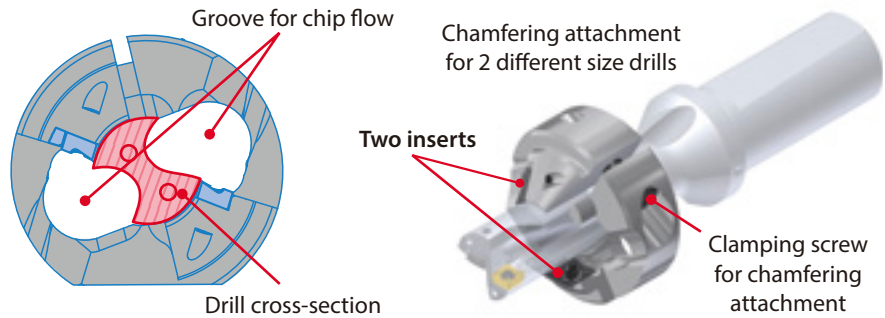
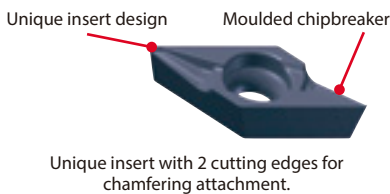

Chattering resistance comparison (In-house evaluation)

Provided good surface finish on the chamfer without chattering

DRV-CH-20 Cutting diameter: Ø20 mm				DRV-CH-20 Smooth surface without chattering
Competitor P Cutting diameter: Ø20 mm				Competitor P Chattering occurred on the chamfer
Cutting conditions	Vc = 100 m/min. f = 0.15 mm/rev.	Vc = 120 m/min. f = 0.10 mm/rev.	Vc = 120 m/min. f = 0.12 mm/rev.	

Cutting diameter Ø20 mm (3D), drilling depth 30 mm, C2.0. Workpiece: C45. Machine: Machining center BT-50.

Chamfering attachment

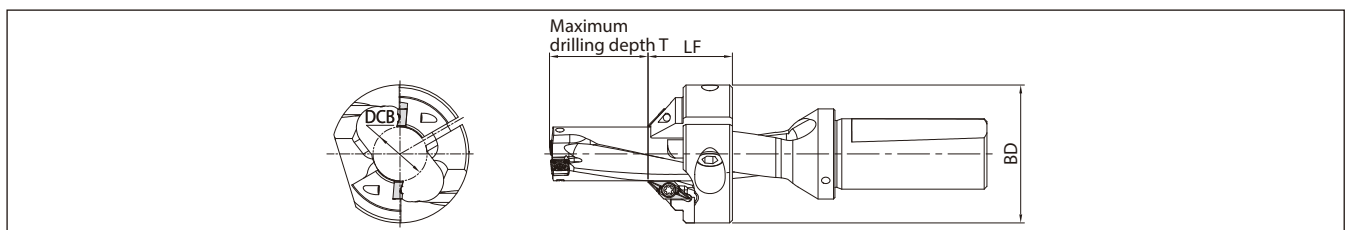

Description	Availability	Applicable drill bodies	Dimensions(mm)			Applicable inserts	Parts							
			BD	DCB	LF		Clamp screw	Wrench	Clamping screw	Wrench				
DRV-CH17	●	S25-DRV165M-○-05 S25-DRV170M-○-05	47	16.2	30	CH0503-45	SB-3080TR	FT-10	HH6X18	LW-5				
DRV-CH18	●	S25-DRV175M-○-05 S25-DRV180M-○-05	47	17.2	30									
DRV-CH19	●	S25-DRV185M-○-05 S25-DRV190M-○-06	49	18.2	30									
DRV-CH20	●	S25-DRV195M-○-06 S25-DRV200M-○-06	49	19.2	30									
DRV-CH21	●	S25-DRV205M-○-06 S25-DRV210M-○-06	49	20.2	30									
DRV-CH22	●	S25-DRV215M-○-06 S25-DRV220M-○-06	49	21.2	30									
DRV-CH23	●	S25-DRV225M-○-07 S25-DRV230M-○-07	51	22.2	30									
DRV-CH24	●	S25-DRV235M-○-07 S25-DRV240M-○-07	51	23.2	30									
DRV-CH25	●	S25-DRV245M-○-07 S25-DRV250M-○-07	53	24.2	30									
DRV-CH26	●	S25-DRV255M-○-07 S25-DRV260M-○-07	53	25.2	30									
DRV-CH27	●	S32-DRV265M-○-09 S32-DRV270M-○-09	64	26	35								HH8X20	LW-6

● : Available

Applicable inserts

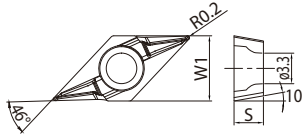
Shape	Description	Dimensions (mm)		MEGACOAT NANO	Applicable chamfering attachment	
		W1	S	PR1535		
		CH0503-45	7.05	3.18	●	DRV-CH○○

● : Available

Maximum drilling depth • Chamfering depths

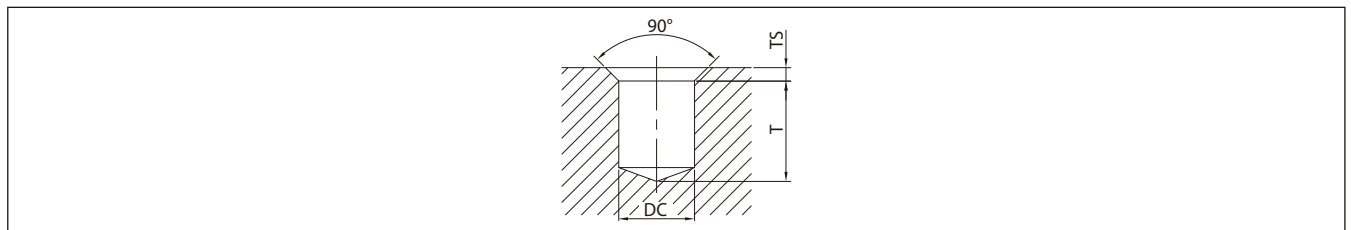

Drilling diameter (mm)	Maximum drilling depth t (mm)					Maximum chamfering depth (mm)	Applicable chamfering attachment
	2D Drill	3D Drill	4D Drill	5D Drill	6D Drill		
DC						2.5	
Ø16.5	0.5	17	33.5	–	–		DRV-CH17
Ø17	1.5	18.5	35.5	52.5	69.5		DRV-CH18
Ø17.5	2.5	20	37.5	–	–		DRV-CH19
Ø18	3.5	21.5	39.5	57.5	75.5		DRV-CH20
Ø18.5	4.5	23	41.5	–	–		DRV-CH21
Ø19	5.5	24.5	43.5	62.5	81.5		DRV-CH22
Ø19.5	6.5	26	45.5	–	–		DRV-CH23
Ø20	7.5	27.5	47.5	67.5	87.5		DRV-CH24
Ø20.5	8.5	29	49.5	–	–		DRV-CH25
Ø21	9.5	30.5	51.5	72.5	93.5		DRV-CH26
Ø21.5	10.5	32	53.5	–	–		DRV-CH27
Ø22	11.5	33.5	55.5	77.5	99.5		
Ø22.5	12.5	35	57.5	–	–		
Ø23	13.5	36.5	59.5	82.5	105.5		
Ø23.5	14.5	38	61.5	–	–		
Ø24	15.5	39.5	63.5	87.5	111.5		
Ø24.5	16.5	41	65.5	–	–		
Ø25	17.5	42.5	67.5	92.5	117.5		
Ø25.5	18.5	44	69.5	–	–		
Ø26	19.5	45.5	71.5	97.5	123.5		
Ø26.5	–	47	–	–	–		
Ø27	16.5	43.5	75.5	97.5	124.5		

How to install chamfering attachment

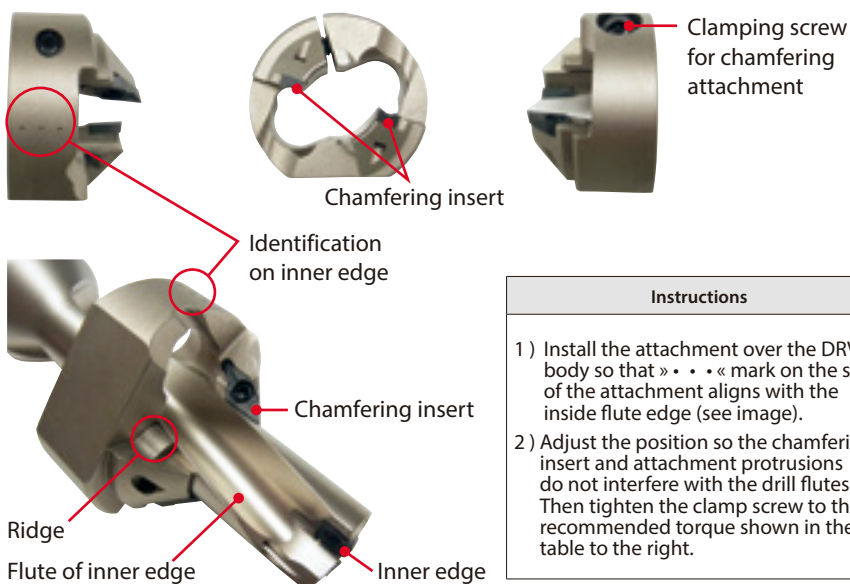

- | Instructions |
|--|
| 1) Install the attachment over the DRV body so that » • • • « mark on the side of the attachment aligns with the inside flute edge (see image). |
| 2) Adjust the position so the chamfering insert and attachment protrusions do not interfere with the drill flutes. Then tighten the clamp screw to the recommended torque shown in the table to the right. |

Recommended torque

Chamfering attachment description	DRV-CH17 ~ CH26	DRV-CH27
Torque (N·m)	10	14
Clamping screw	Hh6×18	Hh8×20
Wrench	Lw-5	Lw-6

Recommended cutting conditions (2D, 3D, 4D) ★ 1st recommendation ☆ 2nd recommendation

■ DRV recommended cutting conditions (wet)

Workpiece	Recommended insert grade (Cutting conditions Vc : m/min.)											Cutting diameter DC (mm)	Holder type (Drilling depth)				Holder type (Drilling depth)			
	PVD coated carbide				CVD coated carbide						DLC coated carbide		2D, 3D				4D			
	PR1225				CA520D				CA415D		PDL025		F (mm/rev.)				F (mm/rev.)			
	GM	GH	XM	SM	GM	GH	XM	SM	GM	GH	SM		GM	GH	XM	SM	GM	GH	XM	SM
Low carbon steel	-	-	★ 120-200	☆ 120-200	-	-	★ 150-280	☆ 150-280	-	-	-	012 - 13.5	-	-	-	0.04-0.06	-	-	-	0.04-0.06
	-	-	-	-	-	-	-	-	-	-	-	014 - 15.5	-	-	0.04-0.09	0.04-0.07	-	-	0.04-0.08	0.04-0.08
	-	-	-	-	-	-	-	-	-	-	-	016 - 18.5	-	-	0.04-0.10	0.04-0.08	-	-	0.04-0.08	0.04-0.08
	-	-	-	-	-	-	-	-	-	-	-	019 - 22	-	-	0.04-0.12	0.04-0.08	-	-	0.04-0.10	0.04-0.08
	-	-	-	-	-	-	-	-	-	-	-	022.5 - 26	-	-	0.04-0.14	0.06-0.10	-	-	0.04-0.12	0.05-0.10
	-	-	-	-	-	-	-	-	-	-	-	026.5 - 32	-	-	0.06-0.14	0.06-0.10	-	-	0.04-0.12	0.05-0.10
	-	-	-	-	-	-	-	-	-	-	-	033 - 39	-	-	0.06-0.14	0.06-0.10	-	-	0.06-0.12	0.05-0.10
	-	-	-	-	-	-	-	-	-	-	-	040 - 60	-	-	0.06-0.16	0.08-0.12	-	-	0.06-0.16	0.05-0.10
Carbon steel	★ 100-180	☆ 100-180	☆ 100-180	☆ 100-180	★ 150-280	☆ 150-280	☆ 150-280	☆ 150-280	-	-	-	012 - 13.5	0.04-0.14	0.04-0.14	-	0.04-0.10	0.04-0.10	0.04-0.10	-	0.04-0.08
	-	-	-	-	-	-	-	-	-	-	-	014 - 15.5	0.04-0.14	0.04-0.14	0.04-0.10	0.04-0.10	0.04-0.10	0.04-0.10	0.04-0.08	0.04-0.08
	-	-	-	-	-	-	-	-	-	-	-	016 - 18.5	0.06-0.16	0.06-0.16	0.06-0.12	0.06-0.12	0.05-0.12	0.05-0.12	0.04-0.10	0.05-0.10
	-	-	-	-	-	-	-	-	-	-	-	019 - 26	0.08-0.20	0.08-0.20	0.06-0.14	0.06-0.14	0.07-0.16	0.07-0.16	0.04-0.12	0.05-0.12
	-	-	-	-	-	-	-	-	-	-	-	026.5 - 32	0.08-0.20	0.08-0.20	0.06-0.14	0.06-0.14	0.07-0.16	0.07-0.16	0.04-0.12	0.05-0.12
	-	-	-	-	-	-	-	-	-	-	-	033 - 39	0.08-0.20	0.08-0.20	0.06-0.16	0.06-0.14	0.07-0.16	0.07-0.16	0.06-0.14	0.05-0.12
	-	-	-	-	-	-	-	-	-	-	-	040 - 60	0.08-0.20	0.08-0.20	0.06-0.18	0.06-0.14	0.07-0.16	0.07-0.16	0.06-0.16	0.05-0.12
	-	-	-	-	-	-	-	-	-	-	-	012 - 13.5	0.04-0.12	0.04-0.12	-	-	0.04-0.10	0.04-0.10	-	-
Alloy steel	★ 100-160	☆ 100-160	☆ 100-160	-	★ 140-220	☆ 140-220	☆ 140-220	-	-	-	-	014 - 15.5	0.04-0.14	0.04-0.14	-	-	0.04-0.10	0.04-0.10	-	-
	-	-	-	-	-	-	-	-	-	-	-	016 - 18.5	0.06-0.16	0.06-0.16	-	-	0.05-0.12	0.05-0.12	-	-
	-	-	-	-	-	-	-	-	-	-	-	019 - 26	0.08-0.20	0.08-0.20	-	-	0.07-0.16	0.07-0.16	-	-
	-	-	-	-	-	-	-	-	-	-	-	026.5 - 32	0.08-0.20	0.08-0.20	-	-	0.07-0.16	0.07-0.16	-	-
	-	-	-	-	-	-	-	-	-	-	-	033 - 39	0.08-0.20	0.08-0.20	-	-	0.07-0.16	0.07-0.16	-	-
	-	-	-	-	-	-	-	-	-	-	-	040 - 60	0.08-0.20	0.08-0.20	-	-	0.07-0.16	0.07-0.16	-	-
	-	-	-	-	-	-	-	-	-	-	-	012 - 13.5	0.04-0.08	0.04-0.08	-	-	0.04-0.07	0.04-0.07	-	-
	-	-	-	-	-	-	-	-	-	-	-	014 - 15.5	0.04-0.08	0.04-0.08	-	-	0.04-0.07	0.04-0.07	-	-
Mould steel	☆ 80-150	★ 80-150	-	-	☆ 130-210	★ 130-210	-	-	-	-	-	016 - 18.5	0.06-0.12	0.06-0.12	-	-	0.05-0.10	0.05-0.10	-	-
	-	-	-	-	-	-	-	-	-	-	-	019 - 26	0.08-0.15	0.08-0.15	-	-	0.06-0.12	0.06-0.12	-	-
	-	-	-	-	-	-	-	-	-	-	-	026.5 - 32	0.08-0.15	0.08-0.15	-	-	0.06-0.12	0.06-0.12	-	-
	-	-	-	-	-	-	-	-	-	-	-	033 - 39	0.08-0.15	0.08-0.15	-	-	0.06-0.12	0.06-0.12	-	-
	-	-	-	-	-	-	-	-	-	-	-	040 - 60	0.08-0.15	0.08-0.15	-	-	0.06-0.12	0.06-0.12	-	-
	-	-	-	-	-	-	-	-	-	-	-	012 - 13.5	-	-	-	0.04-0.10	-	-	-	0.04-0.08
	-	-	-	-	-	-	-	-	-	-	-	014 - 15.5	-	-	-	0.04-0.10	-	-	-	0.04-0.08
	-	-	-	-	-	-	-	-	-	-	-	016 - 18.5	-	-	-	0.06-0.12	-	-	-	0.05-0.11
Stainless steel	-	-	-	★ 70-140	-	-	-	★ 140-200	-	-	-	019 - 26	-	-	-	0.06-0.14	-	-	-	0.06-0.12
	-	-	-	-	-	-	-	-	-	-	-	026.5 - 32	-	-	-	0.06-0.14	-	-	-	0.06-0.12
	-	-	-	-	-	-	-	-	-	-	-	033 - 39	-	-	-	0.06-0.14	-	-	-	0.06-0.12
	-	-	-	-	-	-	-	-	-	-	-	040 - 60	-	-	-	0.06-0.14	-	-	-	0.06-0.12
	-	-	-	-	-	-	-	-	-	-	-	012 - 13.5	0.08-0.14	0.08-0.14	-	-	0.06-0.10	0.06-0.10	-	-
	-	-	-	-	-	-	-	-	-	-	-	014 - 15.5	0.08-0.14	0.08-0.14	-	-	0.06-0.12	0.06-0.12	-	-
	-	-	-	-	-	-	-	-	-	-	-	016 - 18.5	0.08-0.18	0.08-0.18	-	-	0.08-0.16	0.08-0.16	-	-
	-	-	-	-	-	-	-	-	-	-	-	019 - 26	0.08-0.20	0.08-0.20	-	-	0.08-0.18	0.08-0.18	-	-
Gray cast iron	☆ 100-150	★ 100-150	-	-	-	-	-	-	☆ 150-220	★ 150-220	-	026.5 - 32	0.08-0.20	0.08-0.20	-	-	0.08-0.18	0.08-0.18	-	-
	-	-	-	-	-	-	-	-	-	-	-	033 - 39	0.08-0.20	0.08-0.20	-	-	0.08-0.18	0.08-0.18	-	-
	-	-	-	-	-	-	-	-	-	-	-	040 - 60	0.08-0.20	0.08-0.20	-	-	0.08-0.18	0.08-0.18	-	-
	-	-	-	-	-	-	-	-	-	-	-	012 - 13.5	0.08-0.12	0.08-0.12	-	-	0.06-0.10	0.06-0.10	-	-
	-	-	-	-	-	-	-	-	-	-	-	014 - 15.5	0.08-0.12	0.08-0.12	-	-	0.06-0.10	0.06-0.10	-	-
	-	-	-	-	-	-	-	-	-	-	-	016 - 18.5	0.08-0.16	0.08-0.16	-	-	0.08-0.14	0.08-0.14	-	-
	-	-	-	-	-	-	-	-	-	-	-	019 - 26	0.08-0.18	0.08-0.18	-	-	0.08-0.16	0.08-0.16	-	-
	-	-	-	-	-	-	-	-	-	-	-	026.5 - 32	0.08-0.18	0.08-0.18	-	-	0.08-0.16	0.08-0.16	-	-
Nodular cast iron	☆ 80-120	★ 80-120	-	-	-	-	-	-	☆ 120-180	★ 120-180	-	033 - 39	0.08-0.18	0.08-0.18	-	-	0.08-0.16	0.08-0.16	-	-
	-	-	-	-	-	-	-	-	-	-	-	040 - 60	0.08-0.18	0.08-0.18	-	-	0.08-0.16	0.08-0.16	-	-
	-	-	-	-	-	-	-	-	-	-	-	012 - 13.5	-	-	-	0.04-0.12	-	-	-	0.04-0.10
	-	-	-	-	-	-	-	-	-	-	-	014 - 15.5	-	-	-	0.04-0.12	-	-	-	0.04-0.10
	-	-	-	-	-	-	-	-	-	-	-	016 - 18.5	-	-	-	0.06-0.14	-	-	-	0.06-0.12
	-	-	-	-	-	-	-	-	-	-	-	019 - 22	-	-	-	0.08-0.16	-	-	-	0.08-0.15
	-	-	-	-	-	-	-	-	-	-	-	022.5 - 26	-	-	-	0.08-0.18	-	-	-	0.08-0.18
	-	-	-	-	-	-	-	-	-	-	-	026.5 - 32	-	-	-	0.08-0.20	-	-	-	0.08-0.18
Aluminium alloys	-	-	-	-	-	-	-	-	-	-	-	033 - 39	-	-	-	0.08-0.20	-	-	-	0.08-0.18
	-	-	-	-	-	-	-	-	-	-	-	040 - 60	-	-	-	0.08-0.20	-	-	-	0.08-0.18

Internal coolant is recommended.

■ DRV recommended cutting conditions (wet)

Workpiece	Recommended insert grade (Cutting conditions Vc: m/min.)											Cutting diameter DC (mm)	Holder type (Drilling depth)				Holder type (Drilling depth)						
	PVD coated carbide				CVD coated carbide				DLC coated carbide				5D				6D						
	PR1225				CA520D				CA415D				PDL025			f (mm/rev)				f (mm/rev)			
	GM	GH	XM	SM	GM	GH	XM	SM	GM	GH	SM		GM	GH	XM	SM	GM	GH	XM	SM			
Low carbon steel	-	-	★ 120-200	☆ 120-200	-	-	★ 150-280	☆ 150-280	-	-	-	Ø12 - 13.5	-	-	-	0.03-0.05	-	-	-	0.03-0.05			
	-	-	-	-	-	-	-	-	-	-	-	Ø14 - 15.5	-	-	0.04-0.07	0.04-0.06	-	-	0.04-0.06	0.04-0.06			
	-	-	-	-	-	-	-	-	-	-	-	Ø16 - 18.5	-	-	0.04-0.08	0.04-0.06	-	-	0.04-0.06	0.04-0.06			
	-	-	-	-	-	-	-	-	-	-	-	Ø19 - 22	-	-	0.04-0.10	0.04-0.07	-	-	0.04-0.07	0.04-0.07			
	-	-	-	-	-	-	-	-	-	-	-	Ø22.5 - 26	-	-	0.04-0.12	0.04-0.08	-	-	0.04-0.08	0.04-0.07			
	-	-	-	-	-	-	-	-	-	-	-	Ø26.5 - 32	-	-	0.04-0.12	0.04-0.08	-	-	0.04-0.08	0.04-0.07			
	-	-	-	-	-	-	-	-	-	-	-	Ø33 - 39	-	-	0.05-0.12	0.04-0.10	-	-	0.04-0.09	0.04-0.08			
	-	-	-	-	-	-	-	-	-	-	-	Ø40 - 60	-	-	0.06-0.14	0.04-0.10	-	-	0.06-0.12	0.04-0.08			
Carbon steel	★ 100-180	☆ 100-180	☆ 100-180	☆ 100-180	★ 150-280	☆ 150-280	☆ 150-280	☆ 150-280	-	-	-	Ø12 - 13.5	0.04-0.08	0.04-0.08	-	0.04-0.07	0.03-0.05	0.03-0.05	-	0.03-0.05			
	-	-	-	-	-	-	-	-	-	-	-	Ø14 - 15.5	0.04-0.08	0.04-0.08	0.04-0.07	0.04-0.07	0.04-0.06	0.04-0.06	0.04-0.06	0.04-0.06			
	-	-	-	-	-	-	-	-	-	-	-	Ø16 - 18.5	0.05-0.10	0.05-0.10	0.05-0.08	0.05-0.08	0.05-0.08	0.05-0.08	0.05-0.07	0.05-0.07			
	-	-	-	-	-	-	-	-	-	-	-	Ø19 - 26	0.06-0.12	0.06-0.12	0.05-0.10	0.05-0.10	0.06-0.10	0.06-0.10	0.05-0.08	0.05-0.08			
	-	-	-	-	-	-	-	-	-	-	-	Ø26.5 - 32	0.06-0.12	0.06-0.12	0.05-0.12	0.05-0.10	0.06-0.10	0.06-0.10	0.05-0.08	0.05-0.08			
	-	-	-	-	-	-	-	-	-	-	-	Ø33 - 39	0.06-0.12	0.06-0.12	0.05-0.12	0.05-0.10	0.06-0.10	0.06-0.10	0.05-0.08	0.05-0.08			
	-	-	-	-	-	-	-	-	-	-	-	Ø40 - 60	0.06-0.12	0.06-0.12	0.06-0.12	0.05-0.10	0.06-0.10	0.06-0.10	0.06-0.10	0.05-0.08			
	-	-	-	-	-	-	-	-	-	-	-	Ø12 - 13.5	0.04-0.08	0.04-0.08	-	-	0.03-0.05	0.03-0.05	-	-			
Alloy steel	★ 100-160	☆ 100-160	☆ 100-160	-	★ 140-220	☆ 140-220	☆ 140-220	-	-	-	-	Ø14 - 15.5	0.04-0.08	0.04-0.08	-	-	0.04-0.06	0.04-0.06	-	-			
	-	-	-	-	-	-	-	-	-	-	-	Ø16 - 18.5	0.05-0.10	0.05-0.10	-	-	0.05-0.08	0.05-0.08	-	-			
	-	-	-	-	-	-	-	-	-	-	-	Ø19 - 26	0.06-0.12	0.06-0.12	-	-	0.06-0.10	0.06-0.10	-	-			
	-	-	-	-	-	-	-	-	-	-	-	Ø26.5 - 32	0.06-0.12	0.06-0.12	-	-	0.06-0.10	0.06-0.10	-	-			
	-	-	-	-	-	-	-	-	-	-	-	Ø33 - 39	0.06-0.12	0.06-0.12	-	-	0.06-0.10	0.06-0.10	-	-			
	-	-	-	-	-	-	-	-	-	-	-	Ø40 - 60	0.06-0.12	0.06-0.12	-	-	0.06-0.10	0.06-0.10	-	-			
	-	-	-	-	-	-	-	-	-	-	-	Ø12 - 13.5	0.04-0.06	0.04-0.06	-	-	0.03-0.05	0.03-0.05	-	-			
	-	-	-	-	-	-	-	-	-	-	-	Ø14 - 15.5	0.04-0.06	0.04-0.06	-	-	0.04-0.05	0.04-0.05	-	-			
Mould steel	☆ 80-150	★ 80-150	-	-	☆ 130-210	★ 130-210	-	-	-	-	-	Ø16 - 18.5	0.04-0.08	0.04-0.08	-	-	0.04-0.06	0.04-0.06	-	-			
	-	-	-	-	-	-	-	-	-	-	-	Ø19 - 26	0.05-0.10	0.05-0.10	-	-	0.05-0.08	0.05-0.08	-	-			
	-	-	-	-	-	-	-	-	-	-	-	Ø26.5 - 32	0.05-0.10	0.05-0.10	-	-	0.05-0.08	0.05-0.08	-	-			
	-	-	-	-	-	-	-	-	-	-	-	Ø33 - 39	0.05-0.10	0.05-0.10	-	-	0.05-0.08	0.05-0.08	-	-			
	-	-	-	-	-	-	-	-	-	-	-	Ø40 - 60	0.05-0.10	0.05-0.10	-	-	0.05-0.08	0.05-0.08	-	-			
	-	-	-	-	-	-	-	-	-	-	-	Ø12 - 13.5	-	-	-	0.04-0.08	-	-	-	0.03-0.05			
	-	-	-	-	-	-	-	-	-	-	-	Ø14 - 15.5	-	-	-	0.04-0.08	-	-	-	0.04-0.06			
	-	-	-	-	-	-	-	-	-	-	-	Ø16 - 18.5	-	-	-	0.04-0.10	-	-	-	0.04-0.09			
Stainless steel	-	-	-	★ 70-140	-	-	-	★ 140-200	-	-	-	Ø19 - 26	-	-	-	0.06-0.12	-	-	-	0.06-0.10			
	-	-	-	-	-	-	-	-	-	-	-	Ø26.5 - 32	-	-	-	0.06-0.12	-	-	-	0.06-0.10			
	-	-	-	-	-	-	-	-	-	-	-	Ø33 - 39	-	-	-	0.06-0.12	-	-	-	0.06-0.10			
	-	-	-	-	-	-	-	-	-	-	-	Ø40 - 60	-	-	-	0.06-0.12	-	-	-	0.06-0.10			
	-	-	-	-	-	-	-	-	-	-	-	Ø12 - 13.5	0.04-0.10	0.04-0.10	-	-	0.04-0.08	0.04-0.08	-	-			
	-	-	-	-	-	-	-	-	-	-	-	Ø14 - 15.5	0.04-0.10	0.04-0.10	-	-	0.04-0.08	0.04-0.08	-	-			
	-	-	-	-	-	-	-	-	-	-	-	Ø16 - 18.5	0.06-0.12	0.06-0.12	-	-	0.06-0.10	0.06-0.10	-	-			
	-	-	-	-	-	-	-	-	-	-	-	Ø19 - 26	0.06-0.14	0.06-0.14	-	-	0.06-0.12	0.06-0.12	-	-			
Gray cast iron	☆ 100-150	★ 100-150	-	-	-	-	-	-	☆ 150-220	★ 150-220	-	Ø26.5 - 32	0.06-0.14	0.06-0.14	-	-	0.06-0.12	0.06-0.12	-	-			
	-	-	-	-	-	-	-	-	-	-	-	Ø33 - 39	0.06-0.14	0.06-0.14	-	-	0.06-0.12	0.06-0.12	-	-			
	-	-	-	-	-	-	-	-	-	-	-	Ø40 - 60	0.06-0.14	0.06-0.14	-	-	0.06-0.12	0.06-0.12	-	-			
	-	-	-	-	-	-	-	-	-	-	-	Ø12 - 13.5	0.04-0.08	0.04-0.08	-	-	0.03-0.05	0.03-0.05	-	-			
	-	-	-	-	-	-	-	-	-	-	-	Ø14 - 15.5	0.04-0.08	0.04-0.08	-	-	0.04-0.06	0.04-0.06	-	-			
	-	-	-	-	-	-	-	-	-	-	-	Ø16 - 18.5	0.06-0.10	0.06-0.10	-	-	0.06-0.08	0.06-0.08	-	-			
	-	-	-	-	-	-	-	-	-	-	-	Ø19 - 26	0.06-0.12	0.06-0.12	-	-	0.06-0.10	0.06-0.10	-	-			
	-	-	-	-	-	-	-	-	-	-	-	Ø26.5 - 32	0.06-0.12	0.06-0.12	-	-	0.06-0.10	0.06-0.10	-	-			
Nodular cast iron	☆ 80-120	★ 80-120	-	-	-	-	-	-	☆ 120-180	★ 120-180	-	Ø33 - 39	0.06-0.12	0.06-0.12	-	-	0.06-0.10	0.06-0.10	-	-			
	-	-	-	-	-	-	-	-	-	-	-	Ø40 - 60	0.06-0.12	0.06-0.12	-	-	0.06-0.10	0.06-0.10	-	-			
	-	-	-	-	-	-	-	-	-	-	-	Ø12 - 13.5	-	-	-	0.04-0.08	-	-	-	0.04-0.08			
	-	-	-	-	-	-	-	-	-	-	-	Ø14 - 15.5	-	-	-	0.04-0.10	-	-	-	0.04-0.08			
	-	-	-	-	-	-	-	-	-	-	-	Ø16 - 18.5	-	-	-	0.06-0.12	-	-	-	0.06-0.10			
	-	-	-	-	-	-	-	-	-	-	-	Ø19 - 22	-	-	-	0.06-0.14	-	-	-	0.06-0.12			
	-	-	-	-	-	-	-	-	-	-	-	Ø22.5 - 26	-	-	-	0.06-0.16	-	-	-	0.06-0.14			
	-	-	-	-	-	-	-	-	-	-	-	Ø26.5 - 32	-	-	-	0.06-0.16	-	-	-	0.06-0.14			
Aluminium alloys	-	-	-	-	-	-	-	-	-	-	-	Ø33 - 39	-	-	-	0.08-0.16	-	-	-	0.08-0.14			
	-	-	-	-	-	-	-	-	-	-	-	Ø40 - 60	-	-	-	0.08-0.18	-	-	-	0.08-0.16			

Internal coolant is recommended.

Insert grade selection guide

Select CVD for the outer edge when performing high speed and high efficiency machining. Machining for high efficiency, abrasion resistance and long tool life. Select a PVD grade for the outer edge when prioritizing edge toughness, stable machining, and improved surface finish. PVD is recommended for the outer edge if chattering occurs or machining with lathe is not available even if cutting conditions are increased.

1st recommendation (High speed and high efficiency machining)

Outer Edge : CVD (CA520D/CA415D) Inner Edge : PVD (PR1535)



Stable machining oriented (1st recommendation for lathe machining)

Outer Edge : PVD (PR1225) Inner Edge : PVD (PR1535)

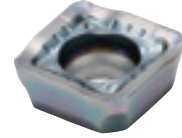

Cutting conditions by application

Application	Plain surface	Slant surface	Half cylindrical	Hole expansion	Pre-drilled surface	Concave surface	Stacked plates	
Workpiece								
Vc (m/min.)	See recommended cutting conditions	120 (PVD insert is recommended for outer edge)						
f (mm/rev.)	See recommended cutting conditions	50% of recommended cutting conditions				Concave Surface: 50% of recommended cutting conditions	Not recommended	
					Continuous Surface: See recommended cutting conditions			
Coolant (Internal coolant)	Yes							

Shape of the hole bottom (mm)

Insert size	DC	A	Insert size	DC	A	Insert size	DC	A	Insert size	DC	A	Insert size	DC	A										
03	12.0	0.70	06	19.0	1.2	07	22.5	1.2	09	26.5	1.2	14	40.0	1.9										
	12.5			19.5			23.0			27.0			41.0											
	13.0			20.0			23.5			27.5			42.0											
	13.5			20.5			24.0			28.0			43.0											
04	14.0	1.0		21.0	1.3	24.5	1.3	25.0		1.3	28.5		1.3	14	44.0	2.0								
	14.5														21.5		25.5	29.0	45.0					
	15.0														22.0		26.0	29.5	46.0					
	15.5																	30.0	47.0					
05	16.0	1.1									14	48.0	2.2											
	16.5											49.0		50.0	51.0	52.0								
	17.0											53.0		54.0	55.0	56.0								
	17.5	1.2																		17	57.0	2.3		
	18.0																				58.0		59.0	60.0
	18.5																							
09	30.5	1.4									17										58.0	2.4		
	31.0																				59.0		60.0	
	31.5																				60.0			
	32.0											61.0												
	32.5											62.0												
	33.0											63.0												
11	33.0	1.5									17	64.0	2.5											
	34.0											65.0												
	35.0											66.0												
	36.0											67.0												
	37.0											68.0												
	38.0											69.0												
17	39.0	1.7									17	70.0	2.6											
	40.0											71.0												
	41.0											72.0												
	42.0											73.0												
	43.0											74.0												
	44.0											75.0												

Common for 2D, 3D, 4D, 5D and 6D drills.
 * The above values are estimate values.
 (Varies by approximately ±0.1 mm depending on workpiece and cutting conditions, etc.)

Cautions for machining

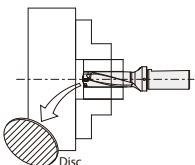

In case of through-hole machining, disc may be generated and ejected outward when drilling a hole. Be sure to install covers to protect against dangers if using a machine without the covers including general-purpose lathes, etc.

Trouble shooting

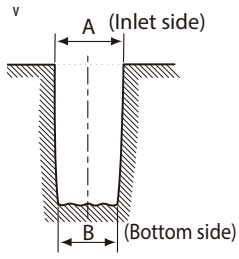
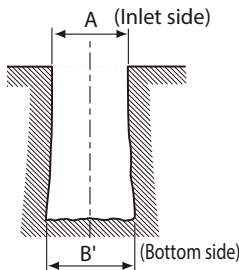
Trouble condition	Condition	Cause	Countermeasures
Hole diameter becomes smaller (At hole bottom)	 <p>There is no problem for inlet, however gradually hole diameter is getting smaller at the bottom.</p> <p>$A > B$</p>	Chip jam (External or internal edge chip stuck)	Change the cutting conditions: <ul style="list-style-type: none"> • Increase the cutting speed • Lower the feed rate P17, P18
Hole diameter becomes larger (At hole bottom)	 <p>There is no problem for inlet, however gradually hole diameter is getting larger at the bottom.</p> <p>$A < B'$</p>	Internal edge chip jam.	Change the cutting conditions: <ul style="list-style-type: none"> • Increase the cutting speed • Lower the feed rate P17, P18 • Check the core height P22, back cover
Hole diameter becomes smaller (From the hole inlet)		Hole diameter is small from inlet. (At turning moment)	Inappropriate adjustment of hole diameter. P22
		No core at internal edge. (No core remains)	Adjust the centre height. P22, back cover

Indication of tool life of MagicDrill

How to judge tool life	Indication of judging tool life
Judgement of tool condition and insert wear	<p>When an insert is new, the toolholder is slightly bent to the side during drilling (therefore, the drill diameter is slightly bigger during drilling). Once drilling is finished, the toolholder will return back to normal size. No tool marks will appear on the finished surface. (This depends on workpiece and cutting condition. Slight tool mark might appear if cutting force on external diameter is too low.)</p> <p>When an insert is at the end of its tool life, gradually the external corner part gets worn out. Also the toolholder does not bend slightly outwards, and it starts to bend inwards. After the drilling is finished, the toolholder returns to the normal position. When taking off a toolholder under this condition, the cutting edge of the insert creates external tool marks on the finished surface of the workpiece.</p>
Checking hole diameter	When hole diameter is measured, suddenly it shows small diameter. In this case, a worn out insert can be the cause and it must be exchange.
Checking the surface on the outlet side	If insert wear progresses, the burrs of penetrated hole entrance becomes bigger. This is a clear indication that the tool must be exchanged.
Variation of drilling noise	Light drilling noise at the beginning turns to brady noise which contains vibration noise.
Variation of vibration	As the end of tool life is getting closer, there is more vibration and the drilling noise changes. However, when drilling smaller diameters these factors are difficult to detect.

Adjustable sleeve (Cutting diameter / Centre height adjustment)

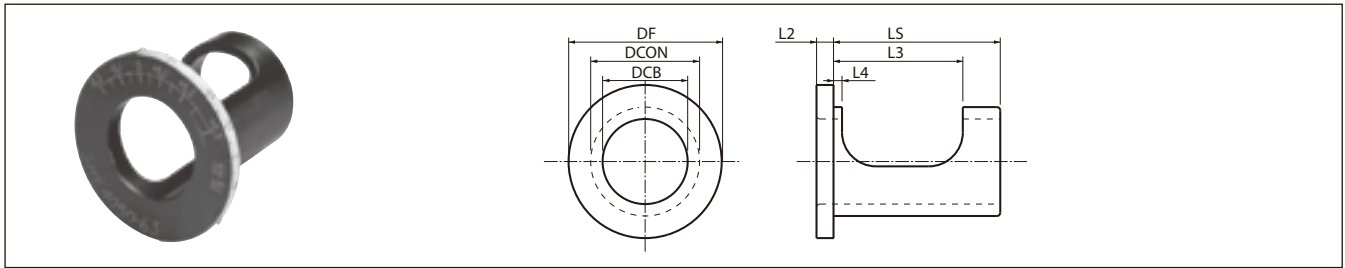

Sleeve dimensions

Description	Availability	Dimensions (mm)								Diameter adjustment range*	Centre height adjustment range
		DCB	DCON	DF	LS	L2	L3	L4			
SHE	2025-43	●	20	25	41	43	4	36	3.0	+0.4 ~ -0.2	+0.2 ~ -0.15
	2532-48	●	25	32	49	48	6	38	2.5	+0.4 ~ -0.2	+0.2 ~ -0.15
	3240-53	●	32	40	58	53	6	43	2.5	+0.4 ~ -0.2	+0.2 ~ -0.15
	4050-63	●	40	50	74	63	6	49	3.0	+0.6 ~ -0.2	+0.3 ~ -0.2

* Diameter adjustment range refers to the cutting diameter.

●: Standard stock

1 Diameter adjustment • For machining centre

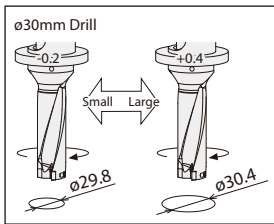

■ Diameter adjustment range (mm)

Shank diameter	Adjustment range
Ø20	+0.4 ~ -0.2
Ø25	
Ø32	
Ø40	+0.6 ~ -0.2

2 Centre height adjustment • Fewer height adjustment problems for lathes

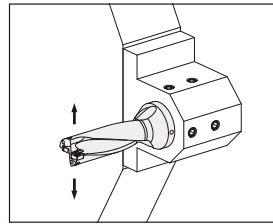

■ Centre height adjustment range (mm)

Shank diameter	Adjustment range
Ø20	+0.2 ~ -0.15
Ø25	
Ø32	
Ø40	+0.3 ~ -0.2

How to use

1 Hole diameter adjustment when drilling

- Align the scale at the flange periphery of the sleeve to the centre of the coolant plug of the drill. (Fig. 1)
- When making the hole diameter bigger, rotate the sleeve in the (+) direction and to make it smaller, rotate the sleeve in the (-) direction.
- When rotating the sleeve, insert the wrench supplied with the drill into the hole on the flange periphery to rotate the sleeve.
- Using the bottom screw of the side-lock arbor, firmly tighten the drill directly through the sleeve's window. The upper screw should be tightened slightly so that the sleeve will not be damaged.

Caution

- Not for use with collet chuck type arbor.
- Check the actual cutting diameter after adjusting.

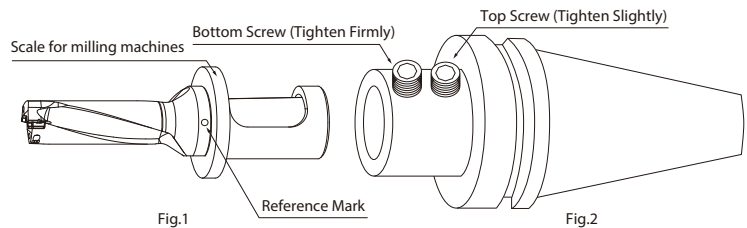

2 Centre-height adjustment for lathes

Most of the problems encountered with a turning lathe are centre-height deviations.

The centre height is appropriate if a core of about 0.5 mm diameter remains at the centre of the hole.

Centre-height adjustment is necessary when no core remains or if the core diameter is more than 1 mm.

- Align the drill with the outer insert face parallel to the X-axis of the tool turret. (Fig. 4)
- Align the scale (for the lathe) on the flange face of the sleeve to the centre of the reference mark.
- When no core remains, rotate the sleeve in the (+) direction to make the core larger, and when the core diameter is more than 1 mm, rotate the sleeve in the (-) direction to make the core smaller.
- When rotating the sleeve, insert the wrench supplied with the drill into the hole of the flange and then rotate the sleeve.
- After Completing the adjustment, tighten the drill directly through the window on the sleeve.

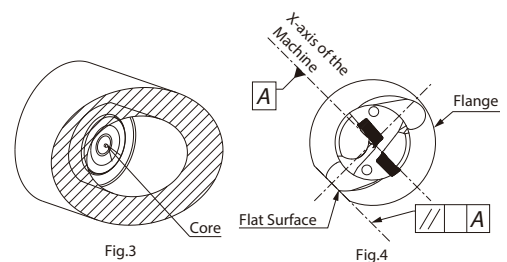

Caution

Depending on amount of the centre height adjustment, the hole diameter may change. It is recommended that the hole diameter is checked after the centre height adjustment.

Lathe installation

1. The top face of the outer insert should be parallel to the X-axis to allow for offset cutting. (Cutting diameter can be changed by moving X-axis.).
2. It is recommended to set the outer insert as shown in Fig. 5 with the outer insert facing the operator. (Fig. 5) (It is also possible to use it by setting it in 180° reverse position). If the lathe has two turrets, when installing the drill into the lower turret, the outer insert should be set to face the operator. (It is also possible to use it by setting at 180° reverse position).

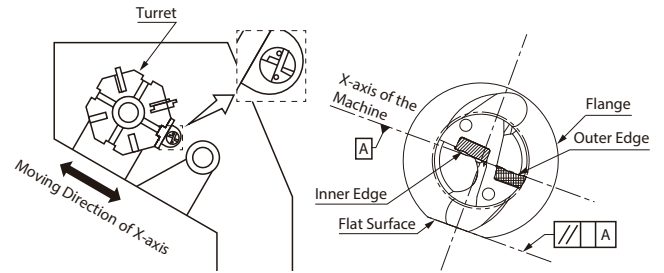

Fig.5 Installed into the Lathe

Cutting diameter adjustment

1 Cutting diameter adjustment

1. Cutting diameter is adjusted by moving X-axis. The moving direction of the X-axis depends on the position of the toolholder.
 2. For making the hole diameter larger, slide the tool along the X-axis toward the outer insert side. (Fig. 6, Fig. 7) For making the hole diameter smaller, slide the tool along the X-axis in the opposite direction. (This movement of the axis is called "Offset") Be sure not to make the hole diameter smaller than the drill diameter by 0.2 mm or more. Otherwise, the toolholder will interfere with the drilled hole. (Fig. 8)
- Example! When using $\varnothing 20$ drill, the hole diameter must not be smaller than 9.8 mm.

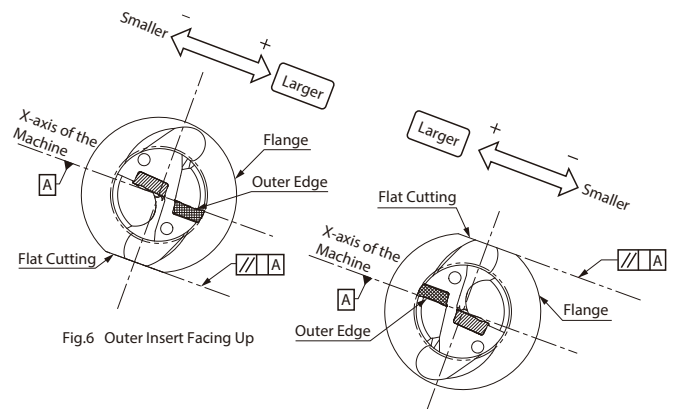

Fig.6 Outer Insert Facing Up

Fig.7 Outer Insert Facing Down

2 Offset limit of the cutting diameter

For the maximum limit of the cutting diameter, refer to "Maximum offset (Radial)" in the Toolholder Dimensions table. (The figure in the Toolholder Dimensions table shows how much it is possible to offset the drill in the radial direction.) Example! When using $\varnothing 20$ drill, for example, it is possible to make a hole up to $\varnothing 21.1$ since "Maximum offset (Radial)" is +0.55 mm.

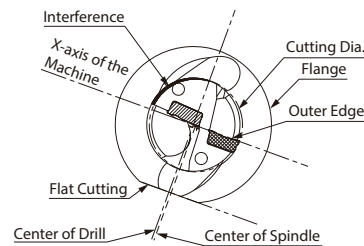

Fig.8 Excessive Offset (For Smaller Hole Diameter)

Centre height adjustment

1 Centre height of the inner insert

When installing inner insert as shown in Fig. 5, it will be set around 0.05 mm below the centre of spindle. (Fig. 9) This is the normal position of the centre height. However, in case that the turret of the lathe is out of the centre of spindle, sometimes the inner insert may be set above or below the centre. For stable machining, it is essential to check the centre height carefully.

2 How to check the centre height

For checking the centre height of the inner insert, see the core which remains at the centre of the bottom of the drilled hole. If the centre height is in the normal position, a core about 0.5 mm in diameter, will remain after machining. (Fig. 10) Adjustment of centre height is required if a large core diameter of 1 mm or more remains. * The drilled hole for verification purposes needs to be machined at approximately 10 mm in depth and at a feed rate of 0.1 mm/rev. or lower.

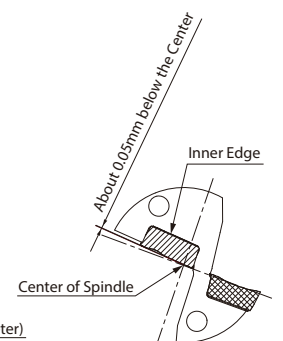

Fig.9 Front View of the Drill

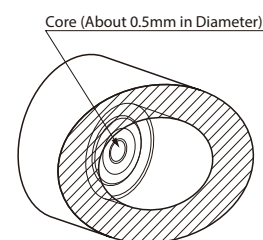

Fig.10 Center Core

3 Centre height adjustment

1. When there are no remaining cores and the vicinity of the drill centre of the inner edge is damaged

This happens when the inner insert is set above the centre height. (Fig. 11)

How to adjust
<p>A. Install the drill rotated by 180° Most problems will be solved by this method. (Fig. 12)</p> <p>B. If the core diameter becomes too large after the above adjustment, install the drill by rotating 90° counter-clockwise as shown in Fig. 13 (outer edge is positioned lower) and adjust the centre height by moving the tool in the X-axis direction. (However, this will make it impossible to adjust the cutting diameter) Caution: When installing the drill in the opposite direction (Outer insert is positioned above), the cutting diameter will become smaller, which may cause the drill body to interfere with the drilled hole. The best solution is to readjust the centre position of the turret itself.</p>

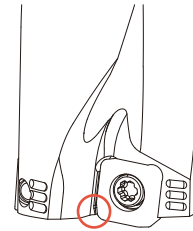

Fig. 11: Insert breakage near the centre of the drill.

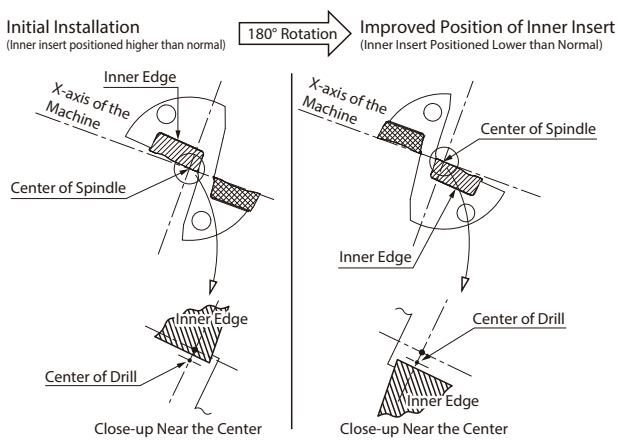

Fig.12

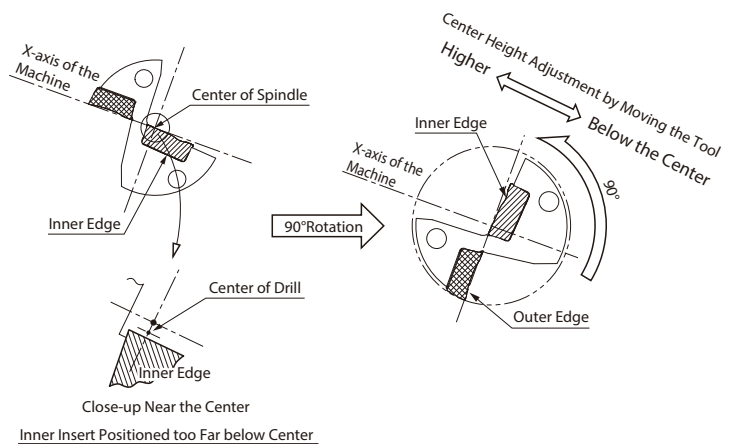

Fig.13

2. Core with excessively large diameter (More than 1 mm)

This occurs when the inner insert is excessively below the centre. This condition causes poor chip evacuation and an adjustment is required.

How to adjust
<p>Install the drill rotating 90° as shown in Fig. 14. (Outer insert is positioned on the upper side) and adjust the centre height by moving tool in the X-axis direction. (However, this will make it impossible to adjust the cutting diameter). Caution: When installing the drill in the opposite direction (outer insert is positioned lower), the cutting diameter will become smaller, which may cause the drill body to interfere with the drilled hole. The best solution is to readjust the centre position of the turret itself.</p>

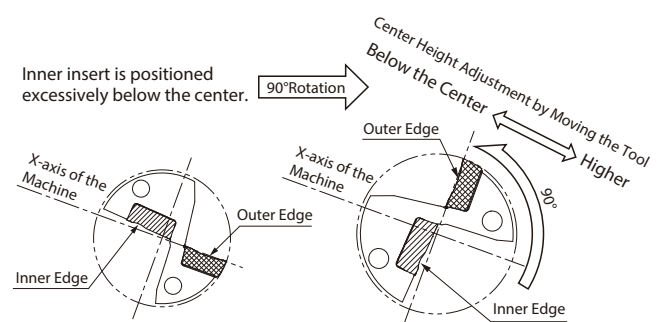

Fig.14

